



Application expertise



Wide & versatile ranges



Configurator & support

Alfa Laval is in the air.

Commercial air heat exchangers from Alfa Laval





# Index

<b>Alfa Laval commercial air heat exchangers</b>	
State of the art production .....	5
<b>Air. The perfect way to cool anything anywhere</b>	
Commercial refrigeration .....	6
Supermarket cooling .....	6
HVAC cooling .....	7
<b>Alfa Laval: a partner you can trust</b>	
Eurovent certification .....	8
Alfa Laval R&D laboratory for air heat exchangers .....	8
<b>Optigo® - Simply fresh, today and tomorrow .....</b>	<b>9</b>
<b>Optigo CS - Slim line commercial air coolers</b>	
Standard configuration .....	10
Optional features .....	11
Fans .....	12
Dimensions.....	13
<b>Optigo CD - Dual discharge air coolers</b>	
Standard configuration .....	14
Optional features .....	15
Fans .....	16
Dimensions.....	17
<b>Optigo CC - Commercial unit coolers</b>	
Standard configuration .....	18
Optional features .....	19
Electrical defrost capacity .....	20
Dimensions.....	21
Fans .....	22
<b>Application drives design: defrost.....</b>	<b>24</b>
<b>Application drives design: anti-corrosion .....</b>	<b>26</b>
<b>Alfa Laval commercial outdoor equipment .....</b>	<b>29</b>
<b>AlfaBlue Junior AG - Commercial condensers</b>	
Standard configuration .....	30
Optional features .....	31
Dimensions.....	31



**AlfaBlue Junior XG - CO<sub>2</sub> gas coolers**

Standard configuration .....32  
 Optional features .....33  
 Dimensions.....33

**AlfaBlue Junior DG - Commercial dry coolers**

Standard configuration .....34  
 Optional features .....35  
 Dimensions.....35

**Alfa-V single row - commercial V-range**

Standard configuration .....36  
 Optional features .....37  
 Dimensions.....37

**Freedom, simplicity and competitive power**

Alfa Laval Anytime .....38  
 AlfaSelect Air .....38  
 Cold room calculator app .....39  
 Product information .....39

**A lifetime of confidence .....40**

**Spare parts**

Optigo CS .....41  
 Optigo CD .....42  
 Optigo CC .....43  
 AlfaBlue Junior .....44

**Quick selection tables**

Cooling capacities condensers .....45  
 Cooling capacities air coolers .....45  
 High glide refrigerants .....45  
 High glide refrigerants and condensers .....46  
 High glide refrigerants and air coolers .....46  
 Air throw .....47  
 Sound pressure dB(A) .....47  
 Stock units .....47

**Selection tables Optigo CS**

CSE fin spacing 4 mm .....48  
 CSE fin spacing 7 mm .....48  
 CSX fin spacing 7 mm .....49



**Selection tables Optigo CD**

CDE fin spacing 4 mm AC fans .....50  
 CDE fin spacing 5.5 mm AC fans .....51  
 CDE fin spacing 7 mm AC fans .....52  
 CDE fin spacing 4 mm EC fans .....53  
 CDE fin spacing 5.5 mm EC fans .....54  
 CDE fin spacing 7 mm EC fans .....55  
 CDX fin spacing 4 mm AC fans .....56  
 CDX fin spacing 7 mm AC fans .....57  
 CDX fin spacing 4 mm EC fans .....58  
 CDX fin spacing 7 mm EC fans .....59

**Selection tables Optigo CC**

CCE fin spacing 4 mm AC fans 1 ph.....60  
 CCE fin spacing 5.5 mm AC fans 1 ph.....61  
 CCE fin spacing 7 mm AC fans 1 ph.....62  
 CCE fin spacing 4 mm AC fans 3 ph.....63  
 CCE fin spacing 7 mm AC fans 3 ph.....65  
 CCE fin spacing 10 mm AC fans 3 ph.....67  
 CCE fin spacing 12 mm AC fans 3 ph.....67  
 CCX fin spacing 4 mm AC fans 1 ph.....68  
 CCX fin spacing 7 mm AC fans 1 ph.....69  
 CCX fin spacing 4 mm EC fans 1 ph.....70  
 CCX fin spacing 7 mm EC fans 1 ph.....71  
 CCX fin spacing 4 mm AC fans 3 ph.....72  
 CCX fin spacing 7 mm AC fans 3 ph.....74

**Selection tables Optigo CCB**

CCBE fin spacing 4 mm AC fans 1 ph .....76  
 CCBE fin spacing 7 mm AC fans 1 ph .....78  
 CCBE fin spacing 4 mm AC fans 3 ph .....80  
 CCBE fin spacing 7 mm AC fans 3 ph .....82  
 CCBE fin spacing 10 mm AC fans 3 ph .....84  
 CCBE fin spacing 12 mm AC fans 3 ph .....84

**Selection tables AlfaBlue Junior AG**

AGS fin spacing 2.1 mm AC fans 3 ph.....85  
 AGL fin spacing 2.1 mm AC fans 3 ph.....86  
 AGQ fin spacing 2.1 mm AC fans 3 ph .....87  
 AGS fin spacing 2.1 mm AC fans 1 ph.....88  
 AGL fin spacing 2.1 mm AC fans 1 ph.....89  
 AGQ fin spacing 2.1 mm AC fans 1 ph .....90

**Other Alfa Laval products .....91**



## Alfa Laval commercial air heat exchangers

Alfa Laval is a leading global provider of specialized products and engineered solutions. We help our customers to heat, cool, separate and transport products such as oil, water, chemicals, beverages, foodstuffs, starch and pharmaceuticals. Our worldwide organization works closely with customers in over a hundred countries to help them stay ahead.

With many decades of experience as a global market leader in plate heat exchangers, Alfa Laval stepped into air heat exchangers back in the 1990s. Acquisition of still well known air heat exchanger brands Helpman® and Fincoil® further widened our product scope and know-how. Alfa Laval is now a leading supplier of air heat exchanger products. Alfa Laval air heat exchangers are used all over the world in a wide range of commercial and industrial applications.

### State-of-the-art production

Alfa Laval commercial air heat exchangers are characterized by high technical standards combined with competitive pricing. And of course easy access to stock products and spares. These products are manufactured in state-of-the-art production sites in Italy and Russia. Our main production site in Alonte (IT) hosts the global distribution center and warehouse for commercial stock products and spares.

Our factories are equipped with the newest machinery and tools for design, production of coils and casing parts, assembly and even the testing of complete units. In a special facility, heat exchangers for CO<sub>2</sub> application are leak tested at 172 bar test pressure.

All Alfa Laval production sites are certified according to ISO 9001 (Quality) and ISO 14001 (Environment). Alfa Laval air heat exchangers are built according to the strictest international standards in terms of safety, energy efficiency and environmental sustainability. All units are given a 2-year guarantee.

The full scope of Alfa Laval commercial air heat exchanger portfolio features Optigo® CS, CD & CC air coolers and a wide range of AlfaBlue Junior and Alfa-V single row condenser, gas cooler and dry cooler models.

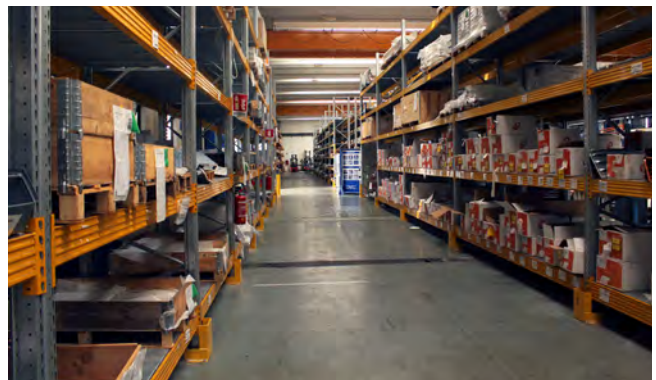



# Air. The perfect way to cool anything anywhere

If your business is to keep things perfectly cool – whether it’s food in a supermarket, people in a shopping mall or produce in a restaurant cold room – air is your element. Cooling and conditioning the ambient air inside a cold room, can give sensitive fresh foods an optimal environment for retaining their freshness – and value. And releasing excess heat to the ambient air outside can bring down indoor temperatures to comfortable levels.

## Commercial refrigeration

Alfa Laval's success in this market is founded on an application-led approach – benefitting both the builders and users of cooling installations. The food industry is a major user of Alfa Laval air heat exchangers. In the agricultural world of vegetables, potatoes and fruit, our air coolers deliver a perfectly balanced capacity/air flow ratio and optimal storage conditions for every type of produce. Close to the end of the supply chain, the retail business is one more major user of Alfa Laval commercial air heat exchangers – highly efficient, often standardized ranges of general purpose unit coolers, air-cooled condensers and dry coolers. Typical application areas are shopping centers, restaurants and warehouses.

Air heat exchangers for direct expansion as well as indirect systems are available.

## Supermarket cooling

Supermarkets, with a combination of walk-in cold rooms, reach-in freezers and cold displays – all operating at different temperatures – are taking advantage of sophisticated cascaded systems using HFO/HFC and CO<sub>2</sub> in the different circuits. And in other refrigerated storage and transit areas throughout the food distribution chain, Alfa Laval's versatile ranges of commercial and industrial air coolers offer energy-efficient, low-noise solutions on every capacity level.



Application	Temperature range	Cooler model & capacity range (SC2)			
		CS 0,5÷7 kW	CCB 1÷55 kW	CC 1÷55 kW	CD 1÷17 kW
General Fresh food	(+0 / +4 °C)	4, 7 mm	-	5.5, 7 mm	5.5, 7 mm
General Frozen food	(-18 / -25 °C)	7 mm	-	7, 10 mm	-
Food preparation	(+4 / +15 °C)	-	5.5, 7 mm	5.5, 7 mm	5.5, 7 mm
Agricultural products	(-2 / +2 °C)	-	7, 10 mm	-	-
Distribution and logistics	(+2 / +12 °C)	-	-	5.5, 7, 10 mm	5.5, 7, 10 mm
Retail and restaurants	(-18 / +4 °C)	4, 7 mm	-	5.5, 7, 10 mm	5.5, 7, 10 mm



### **HVAC cooling**

As a leading supplier to the air conditioning industry, Alfa Laval offers a complete line of commercial dry coolers and condensers for indoor cooling. In combination with our brazed and gasketed plate heat exchangers, they live up to all of these demands.

Keeping people comfortably cool wherever they work, play or relax is the most widespread cooling application. Thousands of buildings around the world are cooled by Alfa Laval's HVAC solutions, based on a number of sophisticated technologies – separately or in combination.

Shopping malls, public buildings, hotels, office complexes, sports arenas, skating rinks – even indoor ski slopes – all pose their own climate challenges. The solution in each case could involve different types of refrigerants, configurations and air-conditioning equipment. In addition to the rigorous performance and efficiency requirements for such systems, their environmental impact is emphasized more and more.

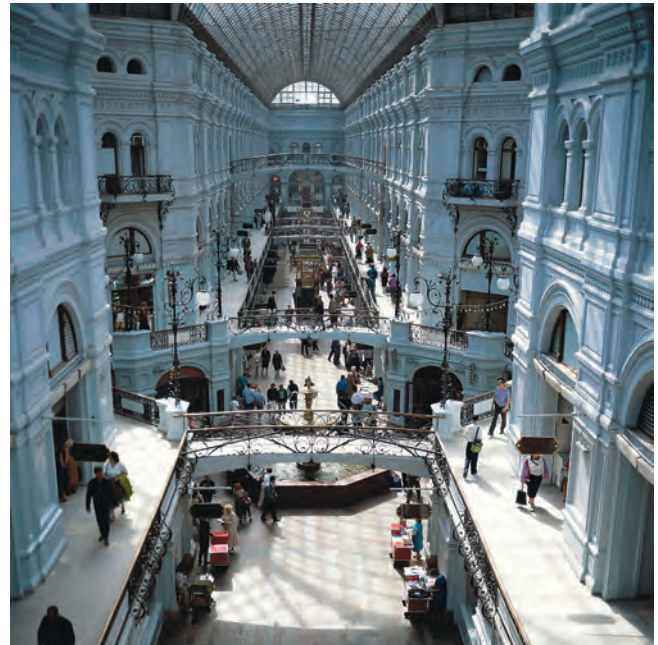

# Alfa Laval: a partner you can trust

## Eurovent certification

Eurovent is Europe's Industry Association for indoor climate (HVAC), refrigeration and process cooling. To meet the requirements on EN regulations and ensure a level playing field for the entire industry, Eurovent initiated certification programmes to create common sets of criteria for the rating of products. Alfa Laval participates in the Eurovent Certify All programmes for DX air coolers, air cooled condensers and dry coolers.

All manufacturers participating in the Eurovent Certify All program are obliged to present a comprehensive list of heat exchanger models/ranges including all required performance data. These files are evaluated by Eurovent and a predefined number of units are selected for testing by independent laboratories. If the test results comply with the relevant standards, all models/ranges are listed in the Eurovent Certification online Directory. Products of each category are subject to regular random testing to verify compliance with catalogue data.

The Eurovent Certify All mark, as used on products and in publications, guarantees that products have been submitted to independent checking and have been accurately rated. For specifiers, installers and end users this implicates that our air heat exchangers will provide a reliable performance. The following product characteristics are rated:

- Standard capacity (using water for dry coolers)
- Fan power input
- Energy ratio & energy class
- Air volume flow
- Liquid side pressure drop for dry coolers
- A-weighted sound power & pressure level for condensers and dry coolers

Eurovent certification applies to all Alfa Laval products that are within the scope of the heat exchangers programme. [www.eurovent-certification.com](http://www.eurovent-certification.com)

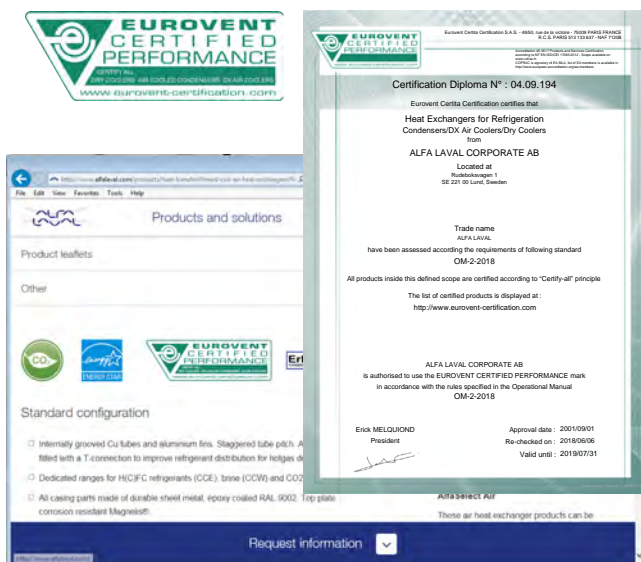

## Alfa Laval R&D laboratory for air heat exchangers

Reliability of Alfa Laval products and performance data is a must for us. To ensure them, extensive testing campaigns are carried out in our R&D Thermal Laboratory. Performances of our existing product ranges are constantly checked, as well as those of new products under development.

Tests in the climatic chamber give us the possibility to develop products with higher performances. A deeper understanding of the heat transfer technology lead to optimized design. Our all new laboratory, built in 2014, allows us to test air coolers according to EN 328, condensers according to EN 327 and dry cooler units according to EN 1048, by satisfying all requirements of EN testing procedures. Temperature range for the tests:  $-40\text{ }^{\circ}\text{C} \div +40\text{ }^{\circ}\text{C}$ .



The laboratory consists of:

- Calorimetric chamber for unit coolers (up to 50 kW), condensers and dry coolers (up to 80 kW) having a large heat exchange capacity.
- Balanced calorimeter for smaller unit coolers (<10 kW).

Thanks to presence of two test plant rigs, it is possible to test both HFC (e.g.: R404A, R507A, etc.), HFO and blends (e.g. R448A, etc.) and CO<sub>2</sub>. The second test plant rig has been set up in 2016 and is especially designed to test CO<sub>2</sub> units, both air coolers and gas coolers. Maximum thermal test pressure for CO<sub>2</sub> is 120 bar: Alfa Laval is one of few air heat exchanger manufacturers with such high standard in-house testing facilities.



In addition it is also possible to test defrost systems for air coolers (including water defrost), droplets tests, and general airflow tests to check air distribution and noise power level according to EN 13487.





# Optigo® – Simply fresh, today and tomorrow

Optigo® is the Alfa Laval platform for commercial air coolers. Common distinctive features for all Optigo products are the newly developed and highly efficient cooler coil in combination with many other features, options and benefits. Optigo comes in low silhouette (CS), dual discharge (CD) and single discharge unit cooler models (CC). Dedicated ranges for HFO/HFC refrigerants (E), brine (W) and CO<sub>2</sub> (X). Optigo coolers are available from stock.



Optigo CS

Optigo CD

Optigo CC

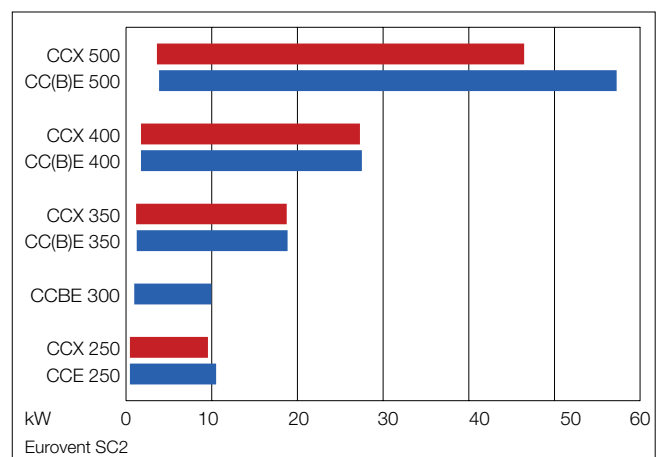
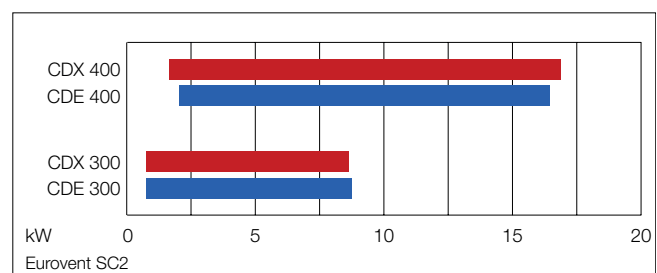
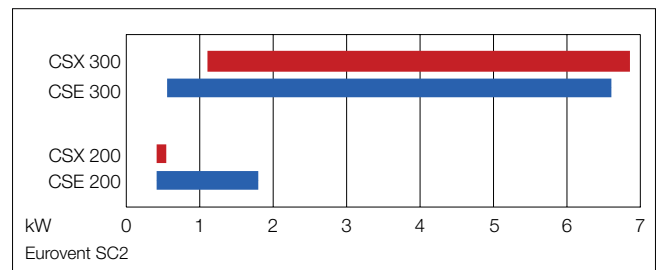



## Optigo CS - Slim line commercial air coolers

Optigo CS are commercial slim line air coolers for general application in small to medium-sized cooling and freezing rooms. CS200 are mini coolers with capacities up to 1.8 kW (SC2), whereas the CS300 line has a different casing geometry and offers cooling capacities up to 6.8 kW (SC2). All CS models are characterised by a low silhouette (only 15 cm for CS200) for the efficient use of cold room space. Optigo CS coolers are available from stock.

- Suitable for all HFO and HFC DX refrigerants (CSE) and CO<sub>2</sub> DX (CSX).
- Room temperatures: +10 to -30 °C.
- Capacity range (SC2): 550 up to 6850 W.
- Air volumes: 380 up to 3800 m<sup>3</sup>/h.

Model	Refrigerant	Design pressure	Test pressure
CSE	HFO/HFC	40 bar	57 bar
CSX	CO <sub>2</sub>	80 bar	120 bar



### Standard configuration

- Innovative coil manufactured from internally grooved Cu tubes, aluminium fins and dedicated thicker tubes for CO<sub>2</sub> application. Tube pitch is 30x26 mm staggered, standard fin spacings 4 and 7 mm. All DX models fitted with a T-connection for better refrigerant distribution.

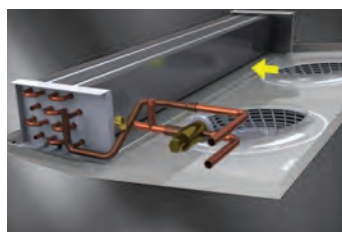

### Benefits

- Available from stock.
- Low silhouette for efficient use of cold room space.
- Sufficient space for expansion valve inside casing.
- Eurovent certified performance (CSE models only).
- Energy efficient EC plug-in fans
- Fans pre-wired to the connection box.
- Two-year product guarantee.
- Easy access to on-line product information.



- Durable aluminium alloy casing, white epoxy coated RAL 9002. Hinged driptray construction, inspection panel for CS200 and removable side panels for CS300. Sufficient room for mounting of expansion valve inside casing. Pre-cut passages for multiple choice connections on both sides and top.

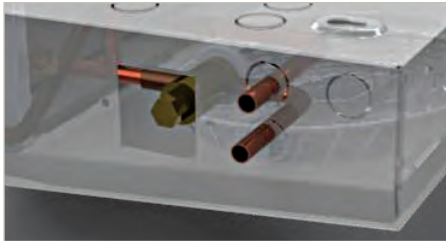

- All Optigo CS models are packed in wood-reinforced cardboard boxes, suitable for safe stacking.



## Optional features

### Electrical defrost **E**

For cold rooms with room temperatures below 4 °C and frost build-up is likely, the application of a defrosting system is advised. For Optigo CS, Alfa Laval supplies stainless steel heater elements mounted against the bottom plate of the coil. The defrost element can be accessed after opening the driptray. The defrost element is connected to separate terminals in the connection box. Electrical defrost is mounted as default for 7 mm models, optional as a separate kit for 4 mm models.

### Code description

<b>C</b>	<b>S</b>	<b>E</b>	<b>H</b>	<b>2</b>	<b>2</b>	<b>B</b>	<b>S</b>	<b>230V</b>	<b>BO</b>	<b>AL</b>	<b>E</b>	<b>CB</b>	-	<b>AL</b>	<b>7.0</b>	<b>CU</b>
1	2	3	4	5	6		7	8	9	10	11	12		13	14	15

- Commercial air cooler - slim line
- Refrigerant system (E=HFO/HFC DX, X=CO<sub>2</sub> DX)
- Fan speed (H=high speed, L=low speed)
- Fan diameter (20=200, 30=300 mm)
- Number of fans (1 to 5)
- Tube rows code (B, C)
- No. of phases (S=1)
- Motor voltage
- Packing (BO=box)
- Casing material (AL= epoxy coated aluminium)
- Defrost system (E=electrical defrost, blank=air defrost)
- Connection box (CB)
- Fin material (AL=aluminium)
- Fin spacing (4.0, 7.0 mm)
- Tube material (CU=copper)



## Fans

All Optigo CS models are fitted with plug-in dual fan speed EC motors. Fans pre-wired to the connection box. Power supply 230/50-60/1. Enclosed design spray-tight fan motors.

### EC fans ø 200 & 300 mm

Fan blade material	Plastic PA, fibre glass reinforced
Fan guard material	Plastic PP
Air direction	Blowing through the coil
Protection class	IP54
Insulation class	B
Condensate discharge	None
Bearings	Maintenance-free ball bearings
Motor protection	Electronics overload protector
Fan speed	Dual fan speed high (H) and low (L)

### Fan specifications

Model	Fan diam. mm	Power supply V	Fan speed H/L RPM	Nom. power W	Nominal current* A
CS200	200	230	2000/1500	37	0.26
CS300	300	230	1300/900	35	0.27

\* At t = 20 °C.





## Dimensions

Model	Dimensions			Connections	
	Length	Mounting	Shipping	OD in/out	
	L	M	volume	CSE	CSX
	mm	mm	m <sup>3</sup>	mm	mm
201B	566	450	0.04	12/12	12/12
202B	1016	900	0.12	12/12	12/12
301B	865	470	0.26	12/12	12/12
301C	865	470	0.26	12/12	12/12
302B	1365	970	0.39	12/14	12/14
302C	1365	970	0.39	16/16	12/14
303B	1865	1470	0.51	16/16	12/14
303C	1865	1470	0.51	16/18	12/14
304C	2365	1970	0.64	16/20	12/14
305C	2865	2470	0.76	16/22	12/14

Detailed drawings showing all required mounting and refrigerant connection dimensions are available for download on [www.alfalaval.com](http://www.alfalaval.com).

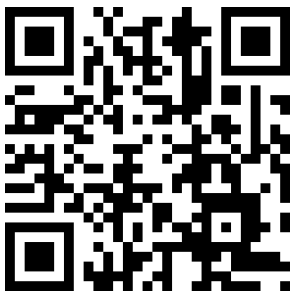

Dimensional drawings

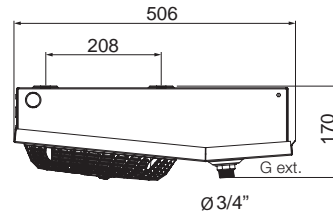

CS200

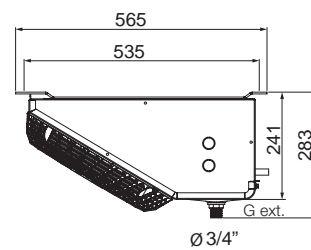
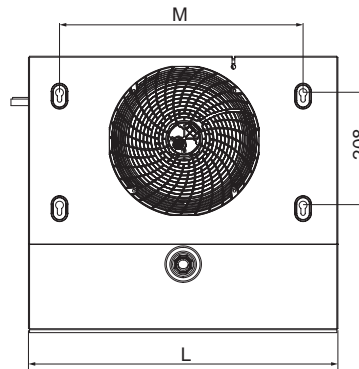

CS300

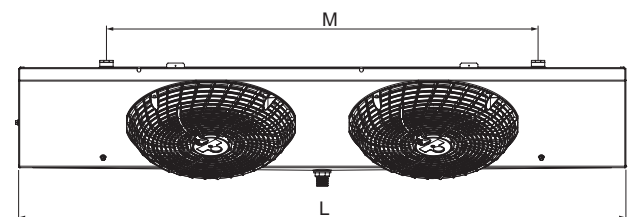



# Optigo CD - Dual discharge air coolers

Optigo CD are commercial dual discharge air coolers for general application in small to medium-sized cooling, freezing and working rooms.

Low air velocity and noise level make them especially suitable for refrigerated working and processing rooms.

Optigo CD coolers are available from stock.

- Suitable for all HFO and HFC DX refrigerants (CDE), brine (CDW) and CO<sub>2</sub> DX (CDX).
- Room temperatures: +10 to -30 °C.
- Capacity range (SC2): 0.8 up to 16.5 kW.
- Air volumes: 600 up to 8400 m<sup>3</sup>/h.



Model	Refrigerant	Design pressure	Test pressure
CDE	HFO/HFC	40 bar	57 bar
CDX	CO <sub>2</sub>	80 bar	114 bar
CDW	Brine	10 bar	14.3 bar

## Standard configuration

- Innovative coil manufactured from internally grooved Cu tubes and aluminium fins, smooth tubing for brine applications and dedicated thicker tubes for CO<sub>2</sub> application. All DX models fitted with a T-connection for better refrigerant distribution.



Model	Fin spacing (mm)			
	4.0	5.5	7.0	10.0
CDE/CDW 300	✓	✓	✓	
CDE 400	✓	✓	✓	
CDW 400	✓	✓	✓	✓
CDX 300	✓	✓	✓	
CDX 400	✓	✓	✓	

- All CD300 are delivered in wood-reinforced cardboard boxes, suitable for safe stacking. All CD400 models are supplied in wooden crates in mounting position.

### Benefits

- Available from stock.
- Compact size for efficient use of cold room space.
- Low air velocity and low noise for comfortable working conditions.
- Eurovent certified performance (CDE models only).
- Energy efficient EC fans.
- Easy-install and maintenance thanks to fully accessible casing construction.
- Two-year product guarantee.
- Easy access to on-line product information.



- Durable aluminium alloy casing, powder epoxy coated RAL 9002. Hinged lateral driptrays with dismountable central drain box. Fully dismountable and openable casing for cleaning purposes. Pre-cut passages for multiple choice connections. Internal air deflectors enhance coil efficiency.



#### Driptray insulation **IS**

Available for CD400 only.

#### Re-heating coil **RH**

Available for CD300 only.

#### Central connection box **CB**

Fan motors wired to central connection box. Standard for EC fan motors.

#### Repair switch **SW**

Available for CD400 only.

#### Stainless steel casing & frame **SS**

#### Fin protection **EP CA**

Fin protection is available for more aggressive climate conditions. The following fin protection types are available:

- Epoxy coated aluminium fins (EP)
- Cataphoresis treatment (CA)

*Cataphoresis ('cathodic electro-deposition') is a process of coating by immersion, based on the movement of charged particles in an electric field (coating) towards an oppositely charged pole that is to be painted (coil).*

*The complete coil is sunk into the coating basin.*

## Optional features

### Electrical defrost **E**

For cold rooms with room temperatures below 4 °C frost build-up is likely and the application of a defrosting system is advised. Electrical defrost for Optigo CD consists of stainless steel heater elements mounted in both coil and driptray. The defrost elements are connected to separate terminals in the connection box.

### Electrical defrost capacities

Model	Tube rows no.	Coil defrost			Driptray defrost		
		heater elements no.	power per heater W	total power W	heater elements no.	power per heater W	total power W
CD301	4/6	-	-	-	2	475	950
CD302	4/6	-	-	-	2	800	1600
CD303	4/6	-	-	-	2	1300	2600
CD304	4/6	-	-	-	2	1600	3200
CD401 B	4	4	500	2000	2	400	800
CD401 C	6	6	500	3000	2	400	800
CD402 B	4	4	1200	4800	2	800	1600
CD402 C	6	6	1200	7200	2	800	1600
CD403 B	4	4	1700	6800	2	1200	2400
CD403 C	6	6	1700	10200	2	1200	2400

### Code description

<b>CD</b>	<b>E</b>	<b>H</b>	<b>E</b>	<b>40</b>	<b>2</b>	<b>.2</b>	<b>B</b>	<b>S</b>	<b>230V</b>	<b>BOP</b>	<b>PC</b>	<b>E</b>	<b>CB</b>	<b>-</b>	<b>AL</b>	<b>7.0</b>	<b>CU</b>	<b>IS</b>
1	2	3	4	5	6	7	8	9	10	11	12	13	14	15	16	17	18	

- Commercial air cooler - dual discharge
- Refrigerant system (E=HFO/HFC DX, W=brine, X=CO<sub>2</sub> DX)
- Fan speed (H=high speed, L=low speed)
- Fan motor type (blank=AC, E=EC)
- Fan diameter (30=300, 40=400 mm)
- Number of fans (1 to 4)
- Tube rows code (B, C)
- CD version
- No. of phases (S=1, T=3)
- Motor voltage
- Packing (BOP=box+pallet, CR=crate)
- Casing material (PC= epoxy coated aluminium, SS stainless steel)
- Defrost system (A=air defrost, E=electrical defrost)
- Connection box (blank=without connection box, CB/CBM=with connection box)
- Fin material (AL=aluminium, EP=epoxy coated aluminium, CA=cataphoresis)
- Fin spacing (4.0, 5.5, 7.0, 10.0 mm)
- Tube material (CU=copper)
- Options



## Fans

Optigo CD coolers are available with 1 to 4 fans fitted with AC or EC fan motors in two fan speed executions (noise levels) H/L. Fan diameters 300 or 400 mm blowing through the coil. Motors with dynamically and statically balanced external rotors.

	EC ø 300 mm	EC ø 400 mm	AC ø 300 mm		AC ø 400 mm	
<b>Fan blade material</b>	Plastic PA, fibre glass reinforced	PP-GF40 plastic	Sheet steel, black coated		Press fitted sheet steel, pp coated	
<b>Fan guard material</b>	Plastic PP	Sheet metal, coated black	Steel, phosphated and black plastic coated		Sheet metal, coated black	
<b>Protection class</b>	IP54	IP54	IP44		IP44	
<b>Insulation class</b>	B	B	B		F	
<b>Condensate discharge</b>	None	None, open rotor	Rotor side		Rotor side	
<b>Bearings</b>	Maintenance-free ball bearings	Maintenance-free ball bearings	Maintenance-free ball bearings		Maintenance-free ball bearings	
<b>Motor protection</b>	Electronics	Electronics	1 ph Thermal overload protector wired internally	3 ph Thermostat switch	1 ph Thermal overload protector wired internally	3 ph Thermostat switch
<b>Fan speed</b>	Dual fan speed high (H) and low (L)	Dual fan speed high (H) and low (L)	-		Dual fan speed high (H) and low (L)	Dual fan speed high (H) and low (L)

### Fan specifications

Fan diameter mm	AC/EC	Poles nr.	Volt V	Phases nr.	Fan speed code	Freq. Hz	Fan speed rpm	Nominal power W	Nominal current* A
300	EC	-	230	1	H	50	1300	35	0.27
					L	50	900		
300	AC	4	230	1	H	50	1320	72	0.32
300	AC	4	400	3	H	50	1300	68	0.14
400	EC	-	230	1	H	50	1080	140	1.15
					L	50	905		
400	AC	4	230	1	H	50	1430	210	1.12
					60	1700	290	1.51	
400	AC	4	400	3	H	50	1440	330	0.72
						60	1670	420	0.84
400	AC	6	230	1	L	50	940	140	0.74
						60	1080	180	0.90
400	AC	6	400	3	L	50	900	120	0.34
						60	970	170	0.42

\* At t = 20 °C.





## Dimensions

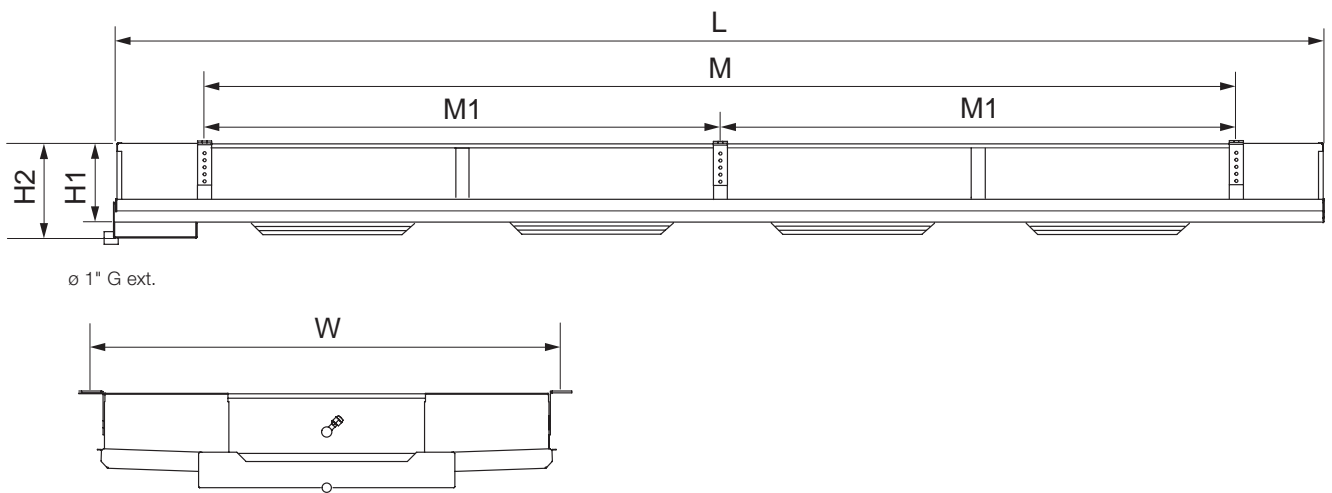

Model	Dimensions (mm)						Shipping
	L	W	H1	H2	M	M1	volume m <sup>3</sup>
CD 301	949	1012	170	203	550	-	0.5
CD 302	1499	1012	170	203	1100	-	0.8
CD 303	2049	1012	170	203	1650	-	1.0
CD 304	2599	1012	170	203	2200	1100	1.5
CD 401	1121	1160	350	400	820	-	1.1
CD 402	1910	1160	350	400	1609	-	1.8
CD 403	2700	1160	350	400	2399	-	2.6

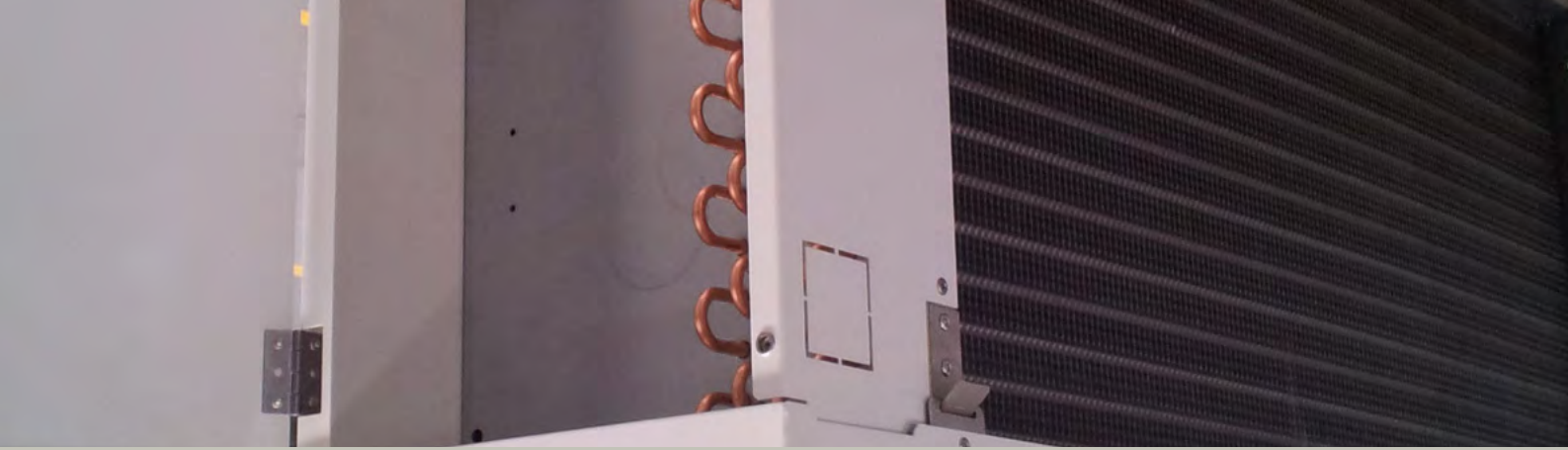

# Optigo CC - Commercial unit coolers

Optigo CC are commercial single discharge unit coolers for general application in small to medium-sized cooling, freezing and working rooms.

A wide range of models make them especially suitable for refrigerated working, processing and storage rooms.

Optigo CC coolers are available from stock.

- Dedicated ranges for HFO and HFC DX refrigerants (E), brine (W) and CO<sub>2</sub> DX (X).
- Available in both draw & blow through execution.
- Room temperatures: +10 to -30 °C.
- Capacity range (SC2): 1 up to 55 kW.
- Air volumes: 770 up to 30000 m<sup>3</sup>/h.



Optigo CC

Model	Refrigerant	Design pressure	Test pressure
CC(B)E	HFO/HFC	40 bar	57 bar
CCX	CO <sub>2</sub>	80 bar	114 bar
CC(B)W	Brine	10 bar	14.3 bar

## Standard configuration

- Internally grooved Cu tubes and aluminium fins, smooth tubing for brine applications and dedicated thicker tubes for CO<sub>2</sub> application. Tube pitch is staggered. All HFO/HFC DX models fitted with a T-connection to improve the refrigerant distribution and for hotgas defrost in coil.



Optigo CCB



T-connection for hot-gas ready

## Benefits

- 80 bar design pressure for CO<sub>2</sub>
- Available from stock.
- Sufficient space for expansion valve inside casing.
- Hotgas defrost ready.
- Eurovent certified performance (CCE models only).
- Energy efficient EC & AC fans.
- Easy-install and maintenance. Vertically adjustable drip tray & removable inner driptray. Hinged side panels.
- Two-year product guarantee.
- Easy access to on-line product information.



Model	Fin spacing (mm)				
	4.0	5.5	7.0	10.0	12.0
CC 250	✓	✓	✓		
CC 300	✓	✓	✓		
CC 350	✓	✓	✓		
CC 400	✓	✓	✓		
CC 500	✓	✓	✓	✓	✓

- Optigo CC251-403 models are delivered in wooden folding boxes, CC404-504 and CCB models in wooden crates. All packings suitable for safe stacking.
- All casing parts made of durable sheet metal, epoxy coated RAL 9002. Top plate corrosion resistant Magnelis®. All models fitted with hinged side panels and aluminium drip tray. Drip tray is adjustable for perfect leveling. Removable internal drip tray for inspection & cleaning.



## Optional features

### Shut up socks **S**

For enhanced defrost efficiency.

### Air sock adapter ring **SR**

Available for CC400 and CC500 draw-through models only.

### Drip tray insulation **IS**

### Fan ring heater **FRH**

### Re-heating coil **RH**



### Central connection box **CB**

Fan motors wired to central connection box.

### Repair switch **SW**

### Stainless steel casing & frame **SS**

### Fin protection **EP CA**

Fin protection is available for more aggressive climate conditions. The following fin protection types are available:

- Epoxy coated aluminium fins (EP)
- Cataphoresis treatment (CA)

*Cataphoresis ('cathodic electro-deposition') is a process of coating by immersion, based on the movement of charged particles in an electric field (coating) towards an oppositely charged pole that is to be painted (coil).*

*The complete coil is sunk into the coating basin.*

## Code description

<b>CC</b>	<b>B</b>	<b>E</b>	<b>H</b>	<b>E</b>	<b>50</b>	<b>1</b>	<b>.2</b>	<b>A</b>	<b>S</b>	<b>230V</b>	<b>CR</b>	<b>SS</b>	<b>E</b>	<b>EP</b>	<b>-</b>	<b>7.0</b>	<b>CU</b>	<b>IS</b>
1	2	3	4	5	6	7	8	9	10	11	12	13	14	15		16	17	18

- Commercial unit cooler
- Air direction (blank=draw through, B=blow through)
- Refrigerant system (E=HFO/HFC DX, W=brine, X=CO<sub>2</sub> DX)
- Fan speed (H=high speed, L=low speed)
- Fan motor type (blank=AC, E=EC)
- Fan diameter (25=250, 30=300, 35=350, 40=400, 50=500 mm)
- Number of fans (1 to 4)
- CC version
- Tube rows code (A, B, C)
- No. of phases (S=1, T=3)
- Motor voltage
- Packing (BO=box, CR=crate)
- Casing material (PC= powder coated, SS stainless steel)
- Defrost system (A=air defrost, E=electrical defrost, HG= hotgas, HG+E= hotgas + electric defrost in drip tray)
- Fin material (AL=aluminium, EP=epoxy coated aluminium, CA=cataphoresis)
- Fin spacing (4.0, 5.5, 7.0, 10.0, 12 mm)
- Tube material (CU=copper)
- Options



## Defrost systems

**E** **HD** **HG**

For cold rooms with room temperatures below 4 °C and where frost build-up is likely, the application of a defrosting system is advised. Available defrost systems are electrical defrost in coil (E) and drip tray (HD), and hotgas defrost in drip tray (HG). Electrical defrost for Optigo CC consists of stainless steel heater elements. The defrost elements are connected to separate terminals in the connection box.

Model	Tube rows no.	Coil defrost			Drip tray defrost					
		heater elements no.	power per heater W	total power W	heater elements no.		total power W			
					std	heavy		std	heavy	
251A	4	2	-	420	840	-	1	-	420	-
251B	6	2	-	420	840	-	1	-	420	-
251C	8	4	-	420	1680	-	1	-	420	-
252A	4	2	-	760	1520	-	1	-	760	-
252B	6	2	-	760	1520	-	1	-	760	-
252C	8	4	-	760	3040	-	1	-	760	-
253A	4	2	-	1120	2240	-	1	-	1120	-
253B	6	2	-	1120	2240	-	1	-	1120	-
253C	8	4	-	1120	4480	-	1	-	1120	-
254A	4	2	-	1470	2940	-	1	-	1470	-
254B	6	2	-	1470	2940	-	1	-	1470	-
301A	4	2	-	420	840	-	1	-	420	-
301B	6	2	-	420	840	-	1	-	420	-
301C	8	4	-	420	1680	-	1	-	420	-
302A	4	2	-	760	1520	-	1	-	760	-
302B	6	2	-	760	1520	-	1	-	760	-
302C	8	4	-	760	3040	-	1	-	760	-
303A	4	2	-	1120	2240	-	1	-	1120	-
303B	6	2	-	1120	2240	-	1	-	1120	-
303C	8	4	-	1120	4480	-	1	-	1120	-
304A	4	2	-	1470	2940	-	1	-	1470	-
304B	6	2	-	1470	2940	-	1	-	1470	-
351A	4	4	-	460	1840	-	1	-	460	-
351B	6	4	-	460	1840	-	1	-	460	-
351C	8	5	-	460	2300	-	1	-	460	-
352A	4	4	-	880	3520	-	1	-	880	-
352B	6	4	-	880	3520	-	1	-	880	-
352C	8	5	-	880	4400	-	1	-	880	-
353A	4	4	-	1290	5160	-	1	-	1290	-
353B	6	4	-	1290	5160	-	1	-	1290	-
353C	8	5	-	1290	6450	-	1	-	1290	-
354A	4	4	-	1700	6800	-	1	-	1700	-
354B	6	4	-	1700	6800	-	1	-	1700	-
354C	8	5	-	1700	8500	-	1	-	1700	-

Model	Tube rows no.	Coil defrost			Drip tray defrost					
		heater elements no.	power per heater W	total power W	heater elements no.		total power W			
					std	heavy		std	heavy	
401A	4	5	7	460	2300	3220	1	2	460	920
401B	6	5	7	460	2300	3220	1	2	460	920
401C	8	8	10	460	3680	4600	1	2	460	920
402A	4	5	7	880	4400	6160	1	2	880	1760
402B	6	5	7	880	4400	6160	1	2	880	1760
402C	8	8	10	880	7040	8800	1	2	880	1760
403A	4	5	7	1290	6450	9030	1	2	1290	2580
403B	6	5	7	1290	6450	9030	1	2	1290	2580
403C	8	8	10	1290	10320	12900	1	2	1290	2580
404A	4	5	7	1700	8500	11900	1	2	1700	3400
404B	6	5	7	1700	8500	11900	1	2	1700	3400
404C	8	8	10	1700	13600	17000	1	2	1700	3400
501A	4	5	7	630	3150	4410	1	2	630	1260
501B	6	5	7	630	3150	4410	1	2	630	1260
501C	8	8	10	630	5040	6300	1	2	630	1260
502A	4	5	7	1220	6100	8540	1	2	1220	1440
502B	6	5	7	1220	6100	8540	1	2	1220	1440
502C	8	8	10	1220	9760	12200	1	2	1220	1440
503A	4	5	7	1810	9050	12670	1	2	1810	3620
503B	6	5	7	1810	9050	12670	1	2	1810	3620
503C	8	8	10	1810	14480	18100	1	2	1810	3620
504A	4	5	7	2400	12000	16800	1	2	2400	4800
504B	6	5	7	2400	12000	16800	1	2	2400	4800
504C	8	8	10	2400	19200	24000	1	2	2400	4800



## Dimensions

Model	Dimensions (mm)					Shipping volume m <sup>3</sup>
	C	H	L	A	B	
<b>Draw-through CC</b>						
CC 251	811	423	418	508	-	0.3
CC 252	1319	423	418	1016	-	0.5
CC 253	1827	423	418	1524	-	0.7
CC 254	2335	423	418	2032	1015	0.9
CC 351	811	602	418	508	-	0.4
CC 352	1319	602	418	1016	-	0.7
CC 353	1827	602	418	1524	-	0.9
CC 354	2335	602	418	2032	1015	1.2
CC 401	1046	668	583	600	-	0.7
CC 402	1646	668	583	1200	-	1.1
CC 403	2246	668	583	1800	-	1.5
CC 404	2846	668	583	2400	1200	2.1
CC 501	1297	854	583	850	-	1.3
CC 502	2147	854	583	1700	-	2.1
CC 503	2997	854	583	2550	-	2.9
CC 504	3847	854	583	3400	1700	3.7
<b>Blow-through CCB</b>						
CCB 301	811	482	609	508	-	0.5
CCB 302	1319	482	609	1016	-	0.7
CCB 303	1827	482	609	1524	-	1.0
CCB 304	2335	482	609	2032	1016	1.2
CCB 351	1046	606	651	600	-	0.7
CCB 352	1646	606	651	1200	-	1.0
CCB 353	2246	606	651	1800	-	1.5
CCB 354	2846	606	651	2400	1200	1.9
CCB 401	1046	665	651	600	-	0.8
CCB 402	1646	665	651	1200	-	1.2
CCB 403	2246	665	651	1800	-	1.6
CCB 404	2846	665	651	2400	1200	2.0
CCB 501	1297	854	902	850	-	1.7
CCB 502	2147	854	902	1700	-	2.7
CCB 503	2997	854	902	2550	-	3.7
CCB 504	3847	854	902	3400	1700	4.7

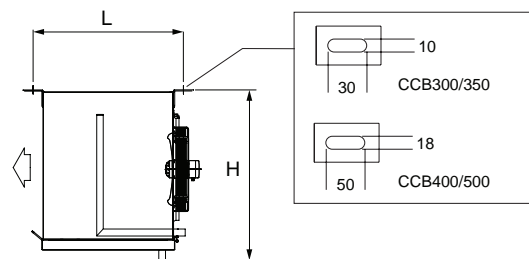
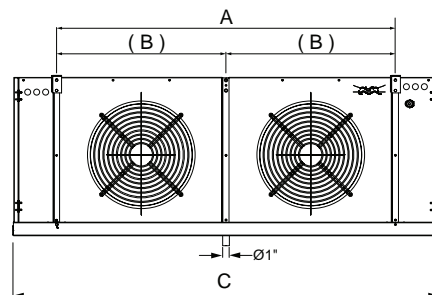
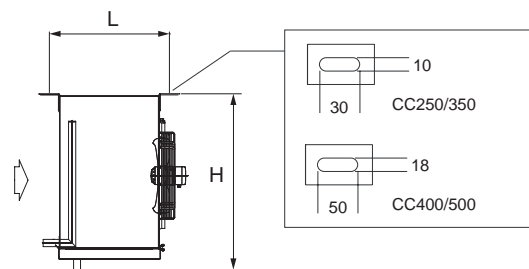
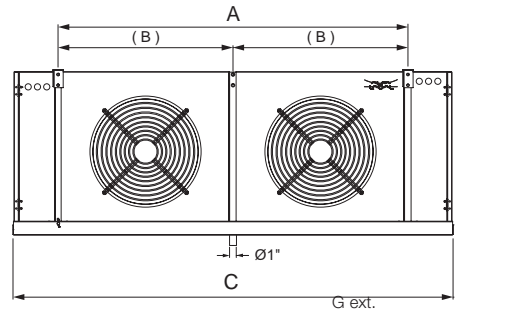



## Fans

	ø 250 mm	ø 300 mm	ø 350 mm	ø 400 mm	ø 500 mm
<b>AC fans 230/50/1</b>					
<b>Fan blade material</b>	Sheet steel, black coated	Sheet steel, black coated	Sheet steel, black coated	Sheet steel, black coated	Metal sheet (PP plastic sprayed*)
<b>Fan guard material</b>	Steel, phosphated and black plastic coated	Steel, phosphated and black plastic coated	Steel, phosphated and black plastic coated	Steel, phosphated and black plastic coated	Steel, phosphated and black plastic coated
<b>Protection class</b>	IP44	IP44	IP44	IP44	IP54
<b>Insulation class</b>	B	B	F	B	F
<b>Condensate discharge</b>	Rotor side	Rotor side	Rotor side	Rotor side	Rotor side
<b>Bearings</b>	Maintenance-free ball bearings	Maintenance-free ball bearings	Maintenance-free ball bearings	Maintenance-free ball bearings	Maintenance-free ball bearings
<b>Motor protection</b>	Thermal overload protector wired internally	Thermal overload protector wired internally	Thermal overload protector wired internally	Thermal overload protector wired internally	Thermal overload protector wired internally
<b>AC fans 230-400/50/3</b>					
<b>Fan blade material</b>	Sheet steel, black coated	Sheet steel, black coated	Sheet steel, black coated	Sheet steel, black coated	Metal sheet (PP plastic sprayed*)
<b>Fan guard material</b>	Steel, phosphated and black plastic coated	Steel, phosphated and black plastic coated	Steel, phosphated and black plastic coated	Steel, phosphated and black plastic coated	Steel, phosphated and black plastic coated
<b>Protection class</b>	IP44	IP44	IP44	IP54	IP54
<b>Insulation class</b>	B	B	F	F	F
<b>Condensate discharge</b>	Rotor side	Rotor side	Rotor side	Rotor side	Rotor side
<b>Bearings</b>	Maintenance-free ball bearings	Maintenance-free ball bearings	Maintenance-free ball bearings	Maintenance-free ball bearings	Maintenance-free ball bearings
<b>Motor protection</b>	Thermostat switch	Thermostat switch	Thermostat switch	Thermostat switch	Thermostat switch
<b>Fan speed</b>	Dual fan speed high (H) and low (L)	-	Dual fan speed high (H) and low (L)	Dual fan speed high (H) and low (L)	Dual fan speed high (H) and low (L)
<b>EC fans</b>					
<b>Fan blade material</b>	Hyblade (fiberglass)	Hyblade (fiberglass)	Hyblade (fiberglass)	Hyblade (fiberglass)	Hyblade (fiberglass)
<b>Fan guard material</b>	Steel, phosphated and black plastic coated	Steel, phosphated and black plastic coated	Steel, phosphated and black plastic coated	Steel, phosphated and black coated	Steel, phosphated and black coated
<b>Protection class</b>	IP54	IP54	IP54	IP54	IP54
<b>Insulation class</b>	B	B	B	B	B
<b>Condensate discharge</b>	None, open rotor	None, open rotor	None, open rotor	Rotor side	Rotor side
<b>Bearings</b>	Maintenance-free ball bearings	Maintenance-free ball bearings	Maintenance-free ball bearings	Maintenance-free ball bearings	Maintenance-free ball bearings
<b>Motor protection</b>	Electronics	Electronics	Electronics	Electronics	Electronics
<b>Fan speed</b>	Dual fan speed high (H) and low (L)	0-10 V speed regulation	0-10 V speed regulation	0-10 V speed regulation	0-10 V speed regulation

# Optigo CC fan specifications

Fan diameter mm	AC/EC	Poles nr.	Volt V	Phases nr.	Fan speed code	Freq. Hz	*Fan speed rpm	*Nominal power W	*Nominal current A
<b>Draw-through AC fans 230/50/1</b>									
250	AC	2	230	1	H	50-60	2250	118	0.65
250	AC	4	230	1	L	50-60	1350	45	0.26
350	AC	4	230	1	H	50-60	1400	130	0.70
350	AC	6	230	1	L	50-60	945	65	0.37
400	AC	4	230	1	H	50-60	1380	219	1.16
400	AC	6	230	1	L	50-60	870	120	0.64
500	AC	4	230	1	H	50-60	1300	680	3.60
500	AC	6	230	1	L	50-60	910	300	1.56
<b>Draw-through AC fans 230-400/50/3</b>									
250	AC	2	230-400	3	H	50-60	2500	100	0.24
350	AC	4	230-400	3	H	50-60	1370	170	0.77
400	AC	4	400	3	H	50-60	1340	280	0.66
400	AC	6	400	3	L	50-60	900	120	0.34
500	AC	4	400	3	H	50-60	1390	720	1.69
500	AC	6	400	3	L	50-60	870	290	0.89
<b>Draw-through EC fans</b>									
250	EC		230	1	H L	50-60	2250 1350	83	0.72
350	EC		230	1	H L	50-60	1400 945	165	1.35
400	EC		230	1	H L	50-60	1380 870	140	1.15
500	EC		230	1	H L	50-60	1300	750	3.40
500	EC		380-480	3	H L	50-60	1390 1180	720	1.41
<b>Blow-through AC fans 230/50/1</b>									
300	AC	4	230	1	H	50-60	1320	72	0.38
350	AC	4	230	1	H	50-60	1400	180	0.97
350	AC	6	230	1	L	50-60	910	74	0.42
400	AC	4	230	1	H	50-60	1380	219	1.16
400	AC	6	230	1	L	50-60	870	120	0.64
500	AC	4	230	1	H	50-60	1300	680	3.60
500	AC	6	230	1	L	50-60	865	220	1.16
<b>Blow-through AC fans 230-400/50/3</b>									
300	AC	4	400	3	L	50-60	1300	68	0.17
350	AC	4	230-400	3	H	50-60	1370	170	0.77
400	AC	4	400	3	H	50-60	1400	229	0.64
500	AC	4	400	3	H	50-60	1390	720	1.69
500	AC	6	400	3	L	50-60	920	260	0.83
<b>Blow-through EC fans</b>									
300	EC		230	1	H L	50-60	1900 1350	170	1.35
350	EC		230	1	H L	50-60	1530 1045	165	1.35
400	EC		230	1	H L	50-60	1250 1000	400	2.60
500	EC		230	1	H L	50-60	1400 900	750	3.40
500	EC		400	3	H L	50-60	1400 1000	980	1.60

\* Specifications for 50 Hz and 230 V for 230-400 fans, 400 V for 380-480 fans. Nominal current at t = 20 °C.

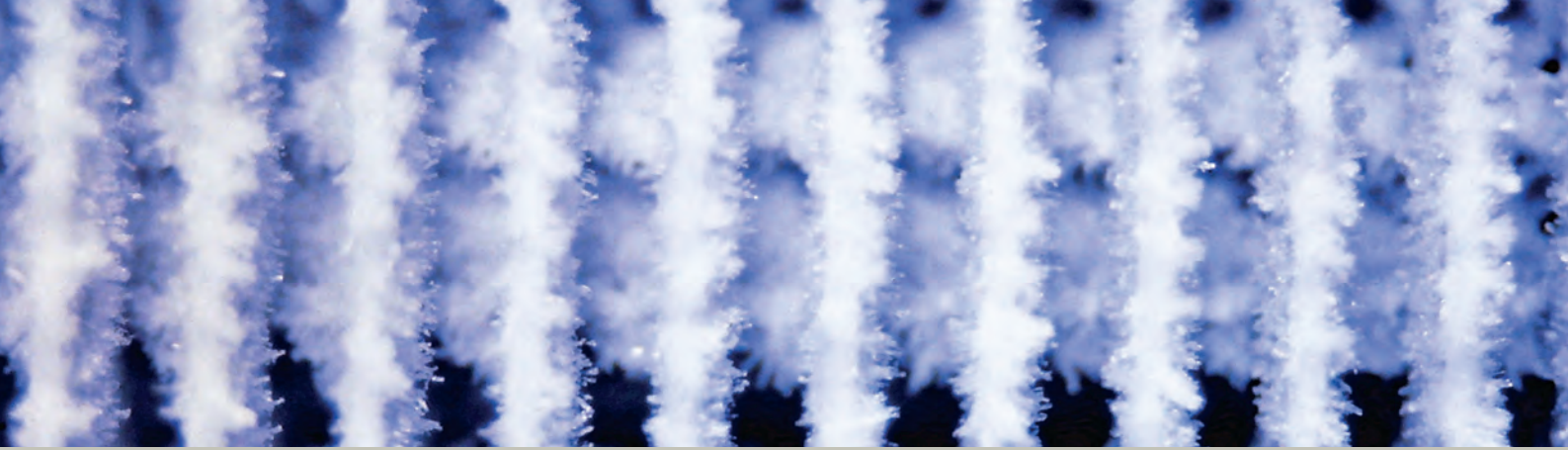

## Application determines design: defrost

When operating air coolers, proper defrosting is crucial. Frost builds up in the cooler coil depending on factors like room temperature, evaporating temperature and relative humidity. If not removed in a correct way, excessive frost build-up will result in a decrease of cooling capacity, air volume, and a significant increase of absorbed fan energy.

About 75% of issues raised with regards to malfunctioning of air coolers are related to defrosting. Common issues encountered include ice buildup in the drip tray and bottom plate, bad air distribution caused by uneven frost or ice buildup in the coil, and reduced airflow. These happen due to possible errors, such as an inadequate defrost system, stopping the defrost period too early, too many defrost periods per day, inefficient time settings of the defrost process, and insufficient checks on the remaining frost or ice in the air cooler.



For Alfa Laval Optigo® commercial air coolers, several defrost systems and defrost related options are available. To obtain optimal results, defrost systems must be correctly designed. Insufficient defrost power or incorrectly distributed heater elements will result in either long defrosting periods (extended interruptions of the cooling process will affect storage conditions and hence product quality!) or incomplete removal of frost. Incomplete frost removal will cause the build-up of solid ice in the coil, resulting in irreparable damage to the air cooler.

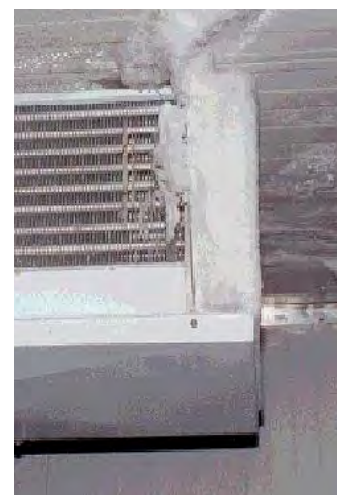



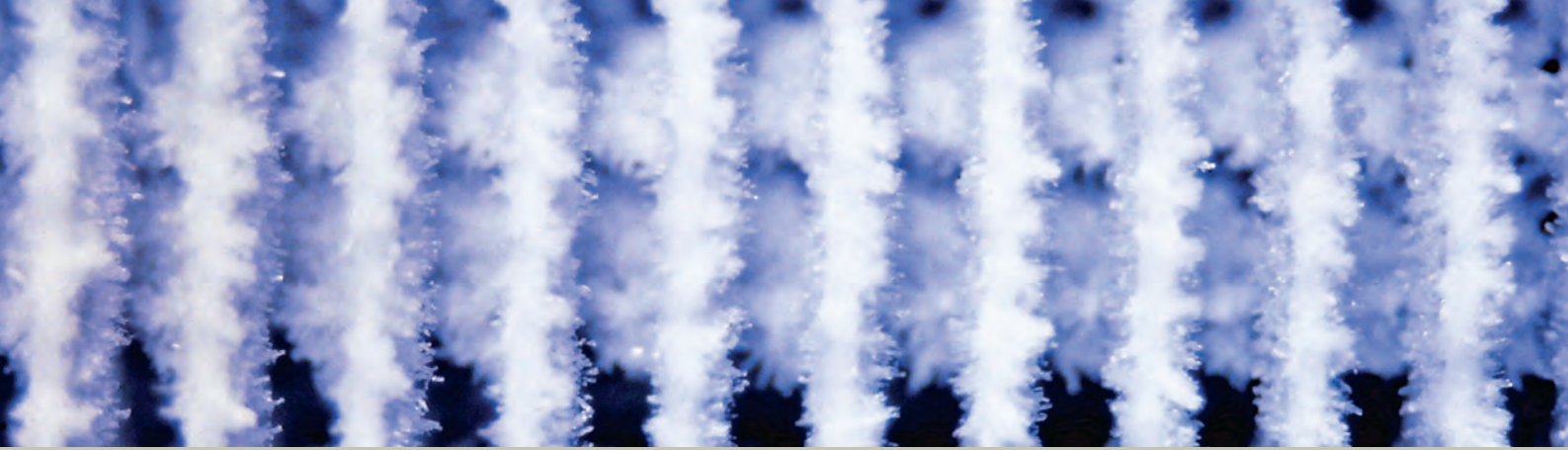

## Defrost systems & application

Defrost system	CC	CD	CS	Application
Forced air defrost	✓	✓	✓	Room temperatures above +2 °C
Electrical defrost	✓	✓	✓	Room temperatures down to -10°C
Electrical defrost heavy	✓			Room temperatures down to -25°C
Hotgas defrost in coil	✓			Room temperatures down to -25°C
Hotgas defrost in coil & driptray	✓			Room temperatures down to -25°C
Hotgas defrost coil + electrical defrost in driptray	✓			Room temperatures down to -25°C
Shut-up sock	✓			Enhance defrost efficiency
Driptray insulation	✓	✓		Enhance defrost efficiency and avoid condensation in the driptray
Fan ring heater	✓			Room temperatures below -10 °C

Defrost system	Benefits	Disadvantages	When to use
<b>Forced air defrost</b>	<ul style="list-style-type: none"> <li>Requires only fan energy</li> <li>No extra investments</li> <li>Low surface temperatures</li> <li>Control can be easily integrated into the cooling process</li> <li>Melting energy is taken from the available air in the cold room, thus generating extra cold air.</li> </ul>	<ul style="list-style-type: none"> <li>Relatively long defrost periods</li> <li>Only suitable for cold room temperatures above +2 °C</li> </ul>	<ul style="list-style-type: none"> <li>Room temperatures above +2 °C.</li> <li>Mostly small cold rooms for meat and agricultural produce</li> </ul>
<b>Electrical defrost</b>	<ul style="list-style-type: none"> <li>Relatively low investments</li> <li>Defrost system control is easy to integrate within the cooling process</li> <li>Reliable</li> <li>Breakdowns can be solved with relative ease</li> </ul>	<ul style="list-style-type: none"> <li>Relatively long defrost periods</li> <li>Use of expensive electrical energy</li> <li>Relatively low energetic yield</li> <li>Relatively high surface temperatures</li> </ul>	<ul style="list-style-type: none"> <li>Forced air circulation not possible</li> </ul>
<b>Hot gas defrost</b>	<ul style="list-style-type: none"> <li>Relatively short defrost periods</li> <li>Energy 'for free'</li> <li>Reliable</li> <li>Relatively low surface temperatures</li> </ul>	<ul style="list-style-type: none"> <li>Relatively high investments</li> <li>Relatively difficult to integrate within the cooling process</li> </ul>	<ul style="list-style-type: none"> <li>Forced air circulation not possible</li> <li>Hot gas is available</li> <li>For larger cooling systems with several coolers</li> </ul>

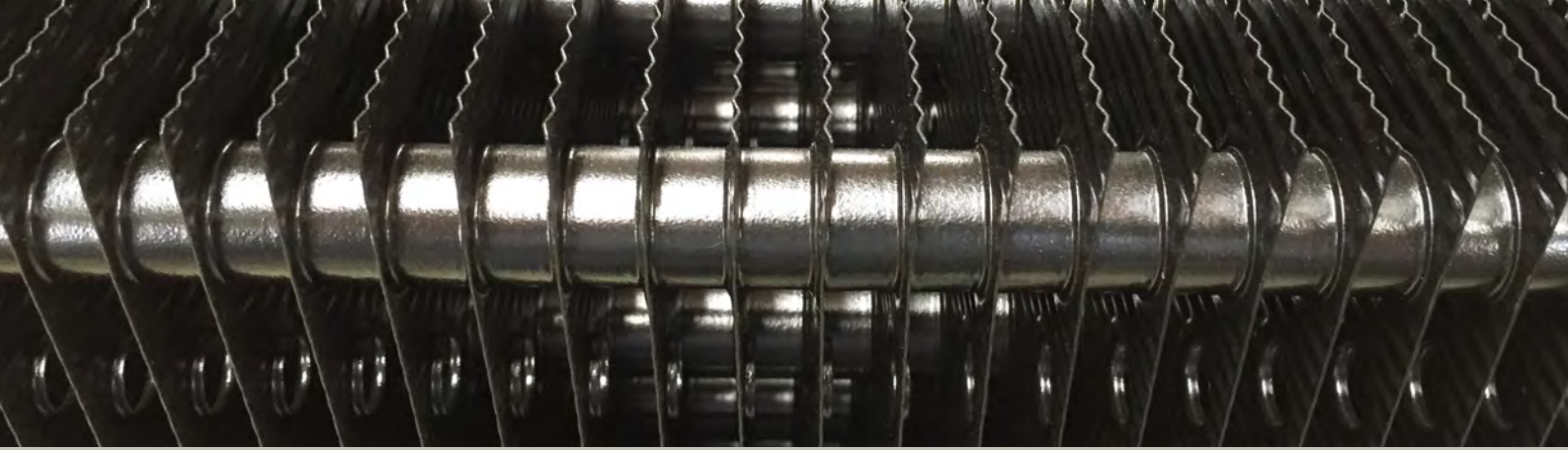

# Application determines design: anti-corrosion

When operating air coolers, the risk of corrosion shall be considered. Corrosive agents might be generated by the products to be refrigerated or by the processes which they are subjected: in those cases proper anti-corrosion protection is crucial.

The table below is to be used as quick reference for selection, and covers most air coolers typical applications. Recommended material combinations are based on experience in the application. No warranty claims can be derived therefrom, as the concentrations of the gases released by the goods to be cooled and the effects of the cleaning agents have a decisive influence on the service life of the units.

Same row means: absolutely same material combinations.

Application		Coil			Casing			Notes
		Tubes	Fins	Coil frame	Internal driptray	External casing	External driptray	
Meat	Normal use	Cu	Al	STD	STD	STD	STD	
	Precooling rooms for half carcasses	Cu	EP/CA	STD	STD	STD	STD	Additional regular washing recommended
	Processing rooms	Cu	Al/EP	STD	STD	STD	STD	Additional regular washing recommended SS casing recommended in case of high hygienic requirements/frequent cleaning
				SS	SS	SS	SS	
	Cold room for smoked products	Cu/SS	Al/EP/CA	STD	STD	STD	STD	Possible aggressive air conditions
				SS	SS	SS	SS	
	Room for salt meat	SS	SWR*/EP/CA	SS	SS	SS	SS	
Cold room for salted products	SS	SWR*/EP/CA	STD	STD	STD	STD		
			SS	SS	SS	SS		
Pickled products	SS	EP	SS	SS	SS	SS	High presence of acids	
Fish	Fresh fish (wet)	Cu	EP/SWR*	STD	STD	STD	STD	
				SS	SS	SS	SS	
	Salting room	SS	SWR*	SS	SS	SS	SS	
	Pickled or salads products	SS	EP/SWR*	SS	SS	SS	SS	High concentration of vinegar
Cold room for smoked fish	Cu / SS	Al/EP	STD	STD	STD	STD	Possible aggressive air conditions	
			SS	SS	SS	SS		
Beverages	Normal use	Cu	Al	STD	STD	STD	STD	
	Fermenting cellars with high SO <sub>2</sub> concentration	Cu/SS	Al/EP/CA	STD	STD	STD	STD	Installation of UC above the fermentation vats
				SS	SS	SS	SS	
Cooling of wine cellars (packed bottles)	CU	Al/EP/CA	STD	STD	STD	STD	Room with bottles only	

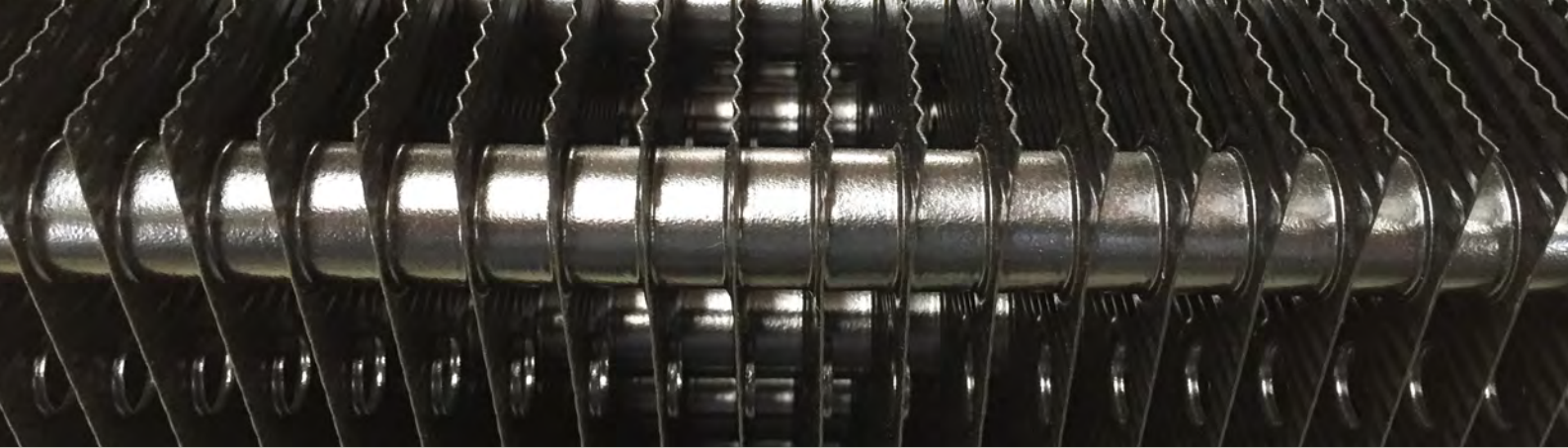

Application		Coil			Casing			Notes
		Tubes	Fins	Coil frame	Internal driptray	External casing	External driptray	
Dairy	Normal use	Cu	Al	STD	STD	STD	STD	
	Storage room for cheese /cream, (e.g. Emmental, Camembert, Parmesan)	SS	EP/CA	STD	STD	STD	STD	Low generating of NH3 and low relative humidity
				SS	SS	SS	SS	
	Storage and ripen room for cheese (e.g. Gruyere, Appenzeller, Daubo, Tilsit, Raclett)	SS	EP/CA	SS	SS	SS	SS	High generating of NH3 and high air humidity (humidification)
	Dairy plants with vapours of milk and butyric acid	Cu	EP/CA	STD	STD	STD	STD	
Packaged cheese	Cu	Al	STD	STD	STD	STD		
Pasta	Normal use	Cu	Al	STD	STD	STD	STD	
	Cold room for fermentation-stop	Cu/SS	EP	SS	SS	SS	SS	High Fin Spacing, due to presence of flour dust in the ambient
	Chill rooms for hot baker's ware exhalling vapours from baking additives	SS	Al	STD	STD	STD	STD	High Fin Spacing, due to presence of flour dust in the ambient
Fruit	Normal use	Cu	Al	STD	STD	STD	STD	Small DT1
	Cold and Storage room for Citrus fruits	Cu	Al	STD	STD	STD	STD	Take care of ventilation
Vegetables & flowers	Normal use	Cu	Al	STD	STD	STD	STD	Small DT1
Others	Deep freezing room (storage)	Cu	Al	STD	STD	STD	STD	Normal product in package
	Logistic warehouse	Cu	Al	STD	STD	STD	STD	Normal product in package

Legenda	
STD	Standard
EP	Epoxy coating
CA	Cataphoresis
Al	Aluminium
SS	Stainless steel 304
Cu	Copper
SWR*	Fins seawater resistant aluminium alloy (SWR) *available only for Optigo CC 500 and Arctigo industrial range





# Alfa Laval commercial outdoor equipment

Commercial air-cooled condensers, gas coolers and liquid coolers. Available in horizontal or vertical setup (AlfaBlue Junior) or as V-type (Alfa-V single row). Available with either copper or stainless steel tubing. The Alfa Laval outdoor portfolio includes a wide variety of design options and accessories.

Alfa-V single row



Condensers capacity range

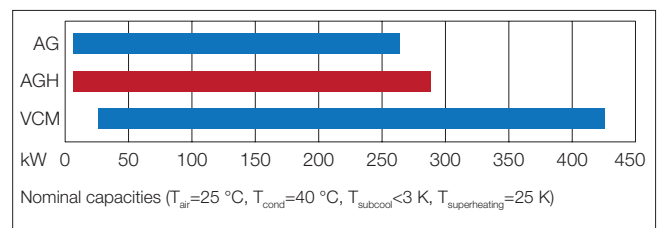

AlfaBlue Junior  
Condenser and gas cooler



Gas coolers capacity range

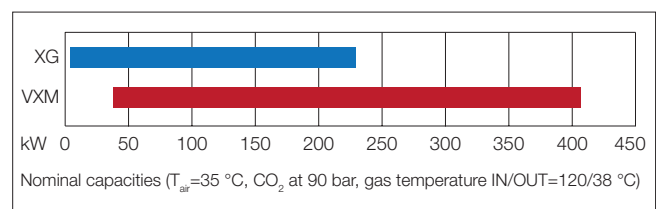

AlfaBlue Junior  
Liquid cooler



Liquid coolers capacity range

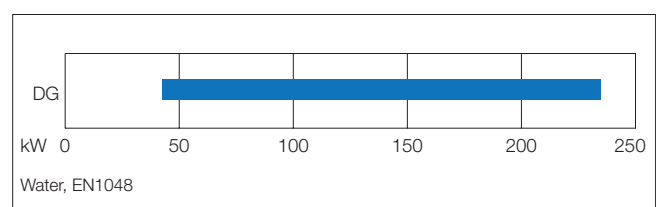



## AlfaBlue Junior AG - Commercial condensers

AlfaBlue Junior is a competitive condenser line that offers excellent performance, allowing easy installation on site and an outstanding integration with other components. High efficient fan motors combine excellent sound characteristics and low energy consumption. AlfaBlue Junior AG condensers can be used in commercial refrigeration and HVAC installations.

- Suitable for all HFO and HFC refrigerants
- Capacity range\*: 5.6 up to 260 kW  
\*  $T_{air}=25\text{ }^{\circ}\text{C}$ ,  $T_{cond}=40\text{ }^{\circ}\text{C}$ ,  $T_{subcool}<3\text{ K}$ ,  $T_{superheating}=25\text{ K}$

Model	Refrigerant	Design pressure	Test pressure
AG	HFO/HFC	33 bar	47 bar
AGH	R410A	45 bar	65 bar



### Standard configuration

- Innovative coil design manufactured from Cu tubes and aluminium turbo fins. Standard fin spacing 2.1 mm. Each heat exchanger is leak tested with dry air and finally supplied with a nitrogen pre-charge.
- Patented coil frame design allowing thermal expansion and offering protection against vibration. Corrosion resistant casing material, powder coated RAL9002. Separated fan sections.
- High efficiency AC or EC fans and low power consumption. Available in three fan diameters 350, 500 & 630 mm, different power supplies (230/50-60/1, 400/50/3, 480/60/3) and four noise levels. Protection class IP 54 according to DIN 40050. AC motors are fitted with integrated thermo contacts to provide reliable protection against thermal overload (terminals in the box).
- A special range of high pressure condensers (design pressure 45 bar) is available with circuiting design optimized for refrigerant R410A. This AGH range has been specifically developed for HVAC applications and may be tailor made for OEM use.



- All units are packed and shipped in horizontal airflow position. AlfaBlue Junior 351, 352, 353, 501 & 502 units are mounted on a wooden pallet and covered with a sturdy cardboard box. All other models are mounted on a wooden pallet, wrapped with plastic foil and covered with an open crate.

#### Benefits

- Reduced refrigerant charge
- Excellent sound characteristics, suitable for residential applications
- Energy efficient
- Easy installation & maintenance
- Eurovent certified performance
- Two-year product guarantee
- Easy access to on-line product information

### Optional features

- Switch on/off (SW)
- Connection box for electrical power connection (CB)
- Fan speed control 230/1 and 400/3 (FP)
- Coil options:
  - Epoxy coated fins (EP)
  - Seawater resistant aluminium AlMg fins (SWR)
  - Copper fins (CU)
  - F-coat treatment (FC)
  - Industrial fins (IF)
  - Fin spacing 2.5 mm. Other fin spacings on request.
- Vibration dampers (VD)
- End covers (CV)
- Mounting feet kit for vertical airflow

### Customization (on request features)

- Split circuits (50/50 %)
- Sub-cooling circuit

### Dimensions

AG(H)		Dimensions mm*					
model	fans	L1	H1	W1	L2	H2	W2
351	1	820	600	548	820	529	390
352	2	1420	600	548	1420	529	390
353	3	2020	600	548	2020	529	390
501	1	1165	890	899	1165	826	512
502	2	2065	890	899	2065	826	512
503	3	2965	890	899	2965	826	512
504	4	3865	890	899	3865	826	512
631	1	1265	1204	1102	1265	1036	760
632	2	2265	1204	1102	2265	1036	760
633	3	3265	1204	1102	3265	1036	760
634	4	4265	1204	1102	4265	1036	760
635	5	5265	1204	1102	5265	1036	760
636	6	6265	1204	1102	6265	1036	760

\* Full dimensional details in instruction manual & website

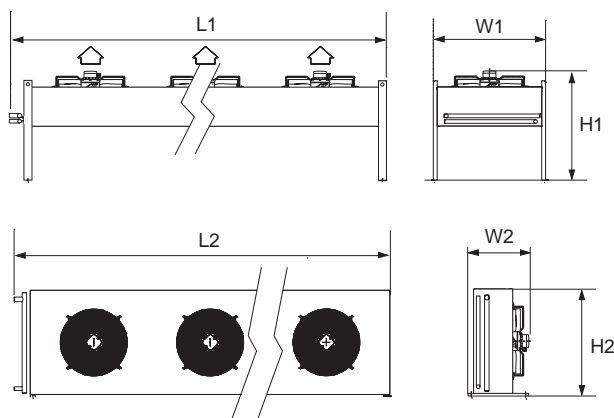

### Code description

<b>AG</b>	<b>H</b>	<b>S(E)</b>	<b>35</b>	<b>2</b>	<b>.2</b>	<b>A</b>	<b>S</b>	<b>H/V</b>	<b>BO</b>	<b>*</b>	<b>-</b>	<b>AL</b>	<b>2.1</b>	<b>CU</b>	<b>R410A</b>	<b>*</b>
1	2	3	4	5	6	7	8	9	10	11		12	13	14	15	16

- AlfaBlue Junior condenser
- High pressure range for R-410A (blank=default, H=R410A)
- Sound level/fan code (S=standard, L=low, Q=quiet, R=residential, E=EC fan motor)
- Fan diameter (35=350, 50=500, 63=630 mm)
- Number of fans (1 to 6)
- Version number
- Tube rows code (A, B, C)
- No. of phases (S=1, D=3)
- Units are suitable for both horizontal and vertical airflow (mounting feet kit required for vertical airflow setup)
- Packing (BO=box, CR=crate)
- Options
- Fin material (AL=aluminium, IF=industrial fins, SWR=AlMg, CU=Copper, EP=epoxy coated aluminium, FC=F-coat)
- Fin spacing (2.1, 2.5 mm)
- Tube material (CU=copper)
- Refrigerant (for H-execution only)
- Options



## AlfaBlue Junior XG - CO<sub>2</sub> gas coolers

AlfaBlue Junior is a competitive gas cooler line that offers excellent performance, allowing easy installation on site and an outstanding integration with other components. High efficient fan motors combine excellent sound characteristics and low energy consumption. AlfaBlue Junior XG gas coolers have been

- Specifically designed for CO<sub>2</sub> refrigerant systems.
- Capacity range\*: 3.2 up to 230 kW.  
\* air temperature=35 °C, CO<sub>2</sub> at 90 bar, gas temperature in/out=120/38°C

Model	Refrigerant	Design pressure	Test pressure
XG	CO <sub>2</sub>	120 bar	172 bar



### Standard configuration

- An innovative coil design based on K65 tubes, Cu alloy connections and aluminium turbo fins, provides excellent heat transfer. Standard fin spacing 2.1 mm. Circuiting design is fully optimized to the thermodynamic properties of CO<sub>2</sub>. Each heat exchanger is leak tested with high pressure nitrogen and finally supplied with a nitrogen pre-charge.
- Patented coil frame design allowing thermal expansion and offering protection against vibration. Corrosion resistant casing material, powder coated RAL9002. Separated fan sections.
- High efficiency AC or EC fans and low power consumption. Available in three fan diameters 350, 500 & 630 mm, different power supplies (230/50-60/1, 400/50/3, 480/60/3) and four noise levels. Protection class IP 54 according to DIN 40050. AC motors are fitted with integrated thermo contacts to provide reliable protection against thermal overload (terminals in the box).
- All units are packed and shipped in horizontal airflow position. AlfaBlue Junior 351, 352, 353, 501 & 502 units are mounted on a wooden pallet and covered with a sturdy cardboard box. All other models are mounted on a wooden pallet, wrapped with plastic foil and covered with an open crate.



### Benefits

- Fully optimized design for CO<sub>2</sub>
- Reduced refrigerant charge
- Excellent sound characteristics, suitable for residential applications
- Energy efficient
- Easy installation & maintenance
- Two-year product guarantee.
- Easy access to on-line product information.



Optional features

- Switch on/off (SW)
- Connection box for electrical power connection (CB)
- Fan speed control 230/1 and 400/3 (FP)
- Coil options:
  - Epoxy coated fins (EP)
  - Seawater resistant aluminium AlMg fins (SWR)
  - Copper fins (CU)
  - F-coat treatment (FC)
  - Industrial fins (IF)
  - Fin spacing 2.5 mm. Other fin spacings on request.
- Vibration dampers (VD)
- End covers (CV)
- Mounting feet kit for vertical airflow
- Stainless steel header tubes for on-site welding connections

Dimensions

XG		Dimensions mm*					
model	fans	L1	H1	W1	L2	H2	W2
351	1	820	600	548	820	529	390
352	2	1420	600	548	1420	529	390
353	3	2020	600	548	2020	529	390
501	1	1165	890	899	1165	826	512
502	2	2065	890	899	2065	826	512
503	3	2965	890	899	2965	826	512
504	4	3865	890	899	3865	826	512
631	1	1265	1204	1102	1265	1036	760
632	2	2265	1204	1102	2265	1036	760
633	3	3265	1204	1102	3265	1036	760
634	4	4265	1204	1102	4265	1036	760
635	5	5265	1204	1102	5265	1036	760
636	6	6265	1204	1102	6265	1036	760

\* Full dimensional details in instruction manual & website

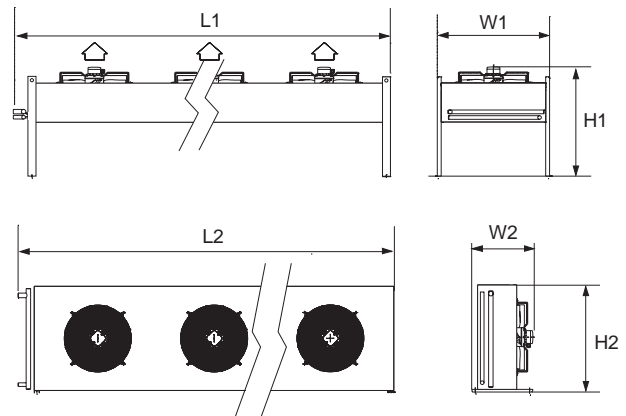

Code description

<b>XG</b>	<b>S(E)</b>	<b>50</b>	<b>2</b>	<b>.1</b>	<b>B</b>	<b>D</b>	<b>H/V</b>	<b>BO</b>	<b>*</b>	-	<b>AL</b>	<b>2.1</b>	<b>K65</b>	<b>*</b>
1	2	3	4	5	6	7	8	9	10		11	12	13	14

- AlfaBlue Junior gas cooler
- Sound level/fan code (T=high performance, S=standard, L=low, Q=quiet, R=residential, E=EC fan motor)
- Fan diameter (35=350, 50=500, 63=630 mm)
- Number of fans (1 to 6)
- Version number
- Tube rows code (A, B, C)
- No. of phases (S=1, D=3)
- Units are suitable for both horizontal and vertical airflow (mounting feet kit required for vertical airflow setup)
- Packing (BO=box, CR=crate)
- Options
- Fin material (AL=aluminium, IF=industrial fins, SWR=AlMg, CU=Copper, EP=epoxy coated aluminium, FC=F-coat)
- Fin spacing (2.1, 2.5 mm)
- Tube material (K65=copper K65)
- Options



# AlfaBlue Junior DG - Commercial Dry Coolers

AlfaBlue Junior DG is a competitive dry cooler line that offers excellent performance, allowing easy installation on site and an outstanding integration with other components. High efficient fan motors combine excellent sound characteristics and low energy consumption. AlfaBlue Junior dry coolers are often used for cooling down condenser water in air-conditioning and refrigeration installations. In the processing industry, dry coolers are suitable for closed circuit cooling of various process liquids.

- Capacity range\*: 45 up to 233 kW  
\*water, EN1048



Model	Design pressure	Test pressure
DG	10 bar	15 bar

## Standard configuration

- Innovative coil design manufactured from Cu tubes and aluminium turbo fins. Standard fin spacing 2.1 mm. Liquid connections externally threaded. Each heat exchanger is leak tested with dry air.
- Patented coil frame design allowing thermal expansion and offering protection against vibration. Corrosion resistant casing material, powder coated RAL9002. Separated fan sections.
- High efficiency AC or EC fans and low power consumption. Available in two fan diameters (500 & 630 mm), different power supplies (230/50-60/1, 400/50/3, 480/60/3) and four noise levels. Protection class IP 54 according to DIN 40050. AC motors are fitted with integrated thermo contacts to provide reliable protection against thermal overload (terminals in the box).
- All units are packed and shipped in horizontal airflow position. AlfaBlue Junior 501 & 502 units are mounted on a wooden pallet and covered with a sturdy cardboard box. All other models are mounted on a wooden pallet, wrapped with plastic foil and covered with an open crate.



### Benefits

- Excellent sound characteristics, suitable for residential applications
- Energy efficient
- Easy installation & maintenance
- Low total cost of ownership
- Two-year product guarantee.
- Easy access to on-line product information.

## Optional features

- Switch on/off (SW)
- Connection box for electrical power connection (CB)
- Fan speed control 230/1 and 400/3 (FT)



- Coil options:
  - Epoxy coated fins (EP)
  - Seawater resistant aluminium alloy fins (SWR)
  - Copper fins (CU)
  - F-coat treatment (FC)
  - Industrial fins (IF)
  - Fin spacing 2.5 mm. Other fin spacings on request.
- Vibration dampers (VD)
- End covers (CV)
- Mounting feet kit for vertical airflow
- Aluminium flanges (FL)



## Dimensions

DG	model	fans	Dimensions mm*					
			L1	H1	W1	L2	H2	W2
	501	1	1165	890	899	1165	826	512
	502	2	2065	890	899	2065	826	512
	503	3	2965	890	899	2965	826	512
	504	4	3865	890	899	3865	826	512
	631	1	1265	1204	1102	1265	1036	760
	632	2	2265	1204	1102	2265	1036	760
	633	3	3265	1204	1102	3265	1036	760
	634	4	4265	1204	1102	4265	1036	760
	635	5	5265	1204	1102	5265	1036	760
	636	6	6265	1204	1102	6265	1036	760

\* Full dimensional details in instruction manual & website

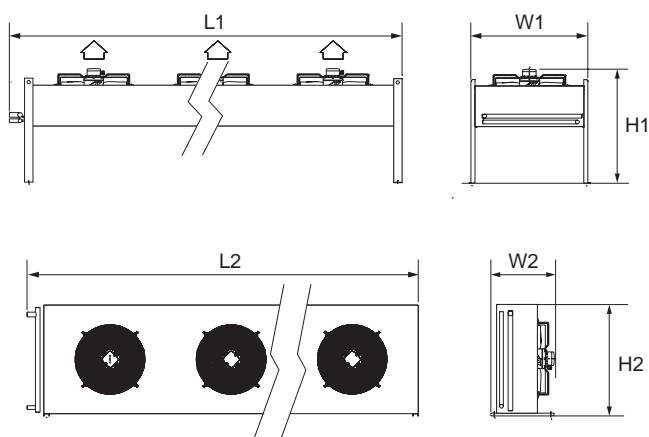

## Code description

DG	S(E)	50	2	.1	B	D	H/V	BO	*	-	AL	2.1	CU	*
1	2	3	4	5	6	7	8	9	10		11	12	13	14

- AlfaBlue Junior dry cooler
- Sound level/fan code (S=standard, L=low, Q=quiet, R=residential, E=EC fan motor)
- Fan diameter (50=500, 63=630 mm)
- Number of fans (1 to 6)
- Version number
- Tube rows code (A, B, C)
- No. of phases (S=1, D=3)
- Units are suitable for both horizontal and vertical airflow (mounting feet kit required for vertical airflow setup)
- Packing (BO=box, CR=crate)
- Options
- Fin material (AL=aluminium, IF=industrial fins, SWR=AlMg, CU=Copper, EP=epoxy coated aluminium, FC=F-coat)
- Fin spacing (2.1, 2.5 mm)
- Tube material (CU=copper)
- Options



## Alfa-V single row - commercial V-range

Alfa Laval supports a sustainable environment. Therefore our Alfa-V Single Row air-cooled condenser and gas coolers range has been designed according to the following principles:

- material wastes reduced to an absolute minimum
- V-angle with its exceptional guiding optimizes airflow
- low coil resistance reduces energy consumption of the fan motors.

Alfa-V Single Row has been specifically designed for commercial refrigeration and air conditioning. Its main purpose is to reject small to medium heat loads in a modest footprint. Alfa-V Single Row also offers many other features to comply with the highest demands in state-of-the-art refrigeration installations in for instance city-size supermarkets.

- Suitable for all HFO/HFC refrigerants and CO<sub>2</sub>
- Capacity range VCM 35 up to 421 kW (SC2)
- Capacity range\* VXM 42 up to 406 kW

\* air temperature=35 °C, CO<sub>2</sub> at 90 bar, gas temperature in/out=120/38°C

Model	Refrigerant	Design pressure	Test pressure
VCM	HFO/HFC	33 bar	47 bar
VXM	CO <sub>2</sub>	120 bar	172 bar

### Standard configuration

- An innovative coil design based copper tubes and aluminium turbo fins provides excellent heat transfer at a minimized refrigerant charge. Standard fin spacing is 2.1 mm. VXM Circuiting design is fully optimized to the thermodynamic properties of CO<sub>2</sub>. Stainless steel header tubes for on-site welding connections.
- Casing material is galvanized steel sheet, pre-painted with an epoxy finish (RAL9002). Separated fan sections.

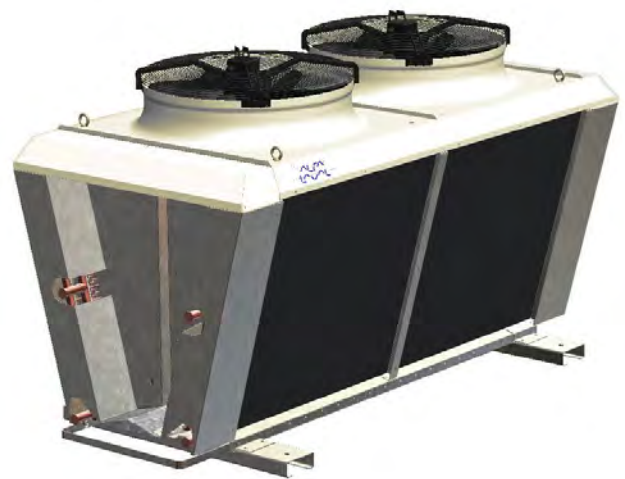

- EC and AC fan motors 400/50/3 available in two fan diameters (800 & 910 mm) and different noise levels. The motors are with external rotor, protection class IP54 according to DIN 40050. Integrated thermal protection by thermo contacts provides reliable protection against thermal overload. Motors are wired to one or more common connection boxes.

### Benefits

- Excellent sound characteristics, suitable for residential applications
- Adjustable mounting feet
- Reduced refrigerant charge
- Energy efficient - low total cost of ownership
- Easy installation & maintenance
- Heavy duty materials for a long product life
- Two-year product guarantee.
- Easy access to on-line product information.

## Dimensions

model	fans no.	Transport dimensions			weight kg	Mounting channels		
		length L mm	height H mm	width W mm		no.	M1 mm	M2 mm
V*M 801	1	1635	1451	1150	230	2	800	-
V*M 802	2	2635	1451	1150	393	2	1800	-
V*M 803	3	3635	1451	1150	557	4	2800	800
V*M 804	4	4635	1451	1150	721	4	3800	1000
V*M 805	5	5635	1451	1150	885	4	4800	1800
V*M 806	6	6635	1451	1150	1049	4	5800	1800
V*M 901	1	1836	1520	1150	260	2	1000	-
V*M 902	2	3036	1520	1150	480	2	2200	-
V*M 903	3	4236	1520	1150	700	4	3400	1200
V*M 904	4	5436	1520	1150	920	4	4600	1300
V*M 905	5	6636	1520	1150	1140	4	5800	2200

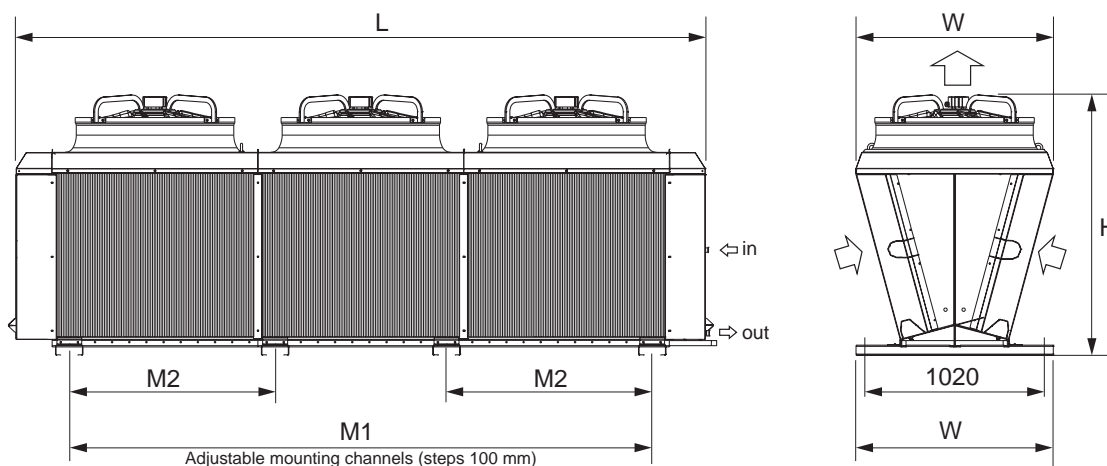

## Optional features

- Multi-circuiting
- Sub-cooling circuit (VCM)
- Non-standard fin spacing
- Coil corrosion protection
  - Epoxy coated fins (EP)
  - Fins seawater resistant aluminium alloy (SWR)
  - Copper fins (CU)
  - F-coat treatment (FC)
  - Fin spacing 2.5 mm. Other fin spacings on request.
- Vibration dampers
- Special fan motors
  - 480/3/60 (IP54)
  - Protection class IP55
  - High-temperature motors
  - High performance EC fans

- Electrical options
  - Switch on/off
  - Motors wired to a common connection box
  - Switchboard (IP56)
  - EMC approval

### Code description

VCM	S(E)	80	3	B	D	*	-	AL	2.1	CU	*
1	2	3	4	5	6	7		8	9	10	11

- Alfa-V Single Row condenser (VCM) / gas cooler (VXM)
- Sound level/fan code (S=standard, L=low, Q=quiet, R=residential, E=EC fan motor)
- Fan diameter (80=800, 90=910 mm)
- Number of fans (1 to 6)
- Tube rows code (A, B, C)
- Fan motor connection (D=delta, Y=star)
- Electrical options
- Fin material (AL=aluminium, EP=epoxy coated aluminium, FC=F-coat)
- Fin spacing (2.1, 2.5 mm)
- Tube material (CU=copper, K65=copper K65)
- Options



## Freedom, simplicity and competitive power

To facilitate product selection, purchasing and even order tracking, Alfa Laval's state-of-the-art selection & ebusiness tools is always available, both on & off-line.

### Alfa Laval Anytime

Find, configure and order your Alfa Laval products with just a few simple clicks, 24/7. In our ebusiness platform Alfa Laval Anytime you can also manage your quotes and orders with net prices, view your order status and follow up on your order history. Apart from this, you will find comprehensive product information. Anytime offers instant access to:

- Product catalogue
- Spare parts finder
- Product documentation
- Your product prices
- Alice: our integrated product selection and configuration tool, featuring the full commercial range
- Easy online order
- Real-time stock & order tracking
- Please contact Alfa Laval and register as an Anytime user.



Shop



Products



Marketing



Training

### AlfaSelect Air

Our off-line computer selection software AlfaSelect Air offers separate modules for mechanical and thermal configuration, as well as instant access to selection and pricing of optional extras. The thermal configuration module offers an integrated cold room calculator. This tool allows users to calculate the required cooling capacity for a cold room and consequently use the calculated value in the air cooler selection procedure.

AlfaSelect Air offers a fully sortable selection output, and an interface that offers multiple language options. The AlfaSelect data sheet printout provides all relevant technical specifications for the selected cooler model, including detailed dimensional drawings. AlfaSelect Air can be easily downloaded via the internet and offers an auto-update function.





### Cold room calculator app

Air cooler capacities should match with the specific conditions of each cold room. So prior to air cooler selection, a calculation must be made to determine the expected heat load for the cold room.

#### Rules of thumb or accuracy?

For making cold room calculations refrigeration installers can rely on experience based and widely used 'rules of thumb' : 15-20 watt/m<sup>3</sup> for a large frozen storage room, 60-70 watt/m<sup>3</sup> for a fresh fruit cooling room, etc. Convenient, quick, but not very accurate.

A more accurate method is to use refined calculation formulas in combination with product data tables. This can be done manually or using commercial cold room calculation software. This is relatively time consuming and if for instance the room door remains open a little longer than planned, so much for calculation accuracy...

#### Quick & easy

To offer a convenient solution, Alfa Laval developed quick & easy cold room calculation software. Our non-academic tool enables customers to make quick and reliable calculations for cold/freezing rooms. With mobile technology rapidly developing, Alfa Laval translated this cold room calculation software into a mobile app for smartphones and tablets. The app is available for free in both Apple & Google app stores.



App name	Alfa Laval Cold Room Calculator
Platform	iOS & Android
Languages	Arabic, Bulgarian, Chinese, Danish, Dutch, English, Finnish, French, German, Italian, Norwegian, Polish, Portuguese, Romanian, Russian, Serbian, Slovenian, Spanish, Swedish, Turkish

### Product information

Comprehensive product information is available on our website [www.alfalaval.com](http://www.alfalaval.com) including product leaflets, manuals, certificates and brochures. The site also offers CAD drawings, electrical connections and high-resolution product images available for download.

Alfa Laval Cold Room Calculator





## A lifetime of confidence

Alfa Laval offers worldwide support from product and application specialists via 103 sales offices in 55 countries. Our offer is comprehensive and consists of a wide portfolio of services such as high quality spare parts, reconditioning, on-site services, reliable stock, upgrades, consulting services, training, etc.

Spare parts are available through Alfa Laval e-business tools, 24/7, for our partners. Our service package is tailored to meet your performance and process needs and guarantees that operational design conditions are met. It also supports cost control by allowing specific settings of air ventilation, defrost cycles etc.

### 360° service offering

At Alfa Laval, we're dedicated to ensuring your equipment performs at its optimum throughout its lifetime. This is why we have a 360° service offering anytime, anywhere.

#### *Start-up*

Our commissioning support team ensures your equipment goes into production as smoothly and safely as possible. Our staff will ensure that global guidelines and instructions are met and will consider the start-up complete only when your process is optimized.

#### *Support*

Spare part selection and ordering is made simpler with our e-business tools, accessible via our sales offices or service partners.

#### *Maintenance*

The normal and continuous operation of air heat exchangers will inevitably lead to it getting dirty or ice-clogged (improper defrost). Such situations can lead to the reduction of the heat exchanger's performance. Cleaning services, parts exchange, or repair are services that might be appropriate in this case.

#### *Improvements*

When your equipment needs to be replaced, Alfa Laval specialists can assist you in making the best choice. Our replacement and retrofit services ensure that your production can continue to operate without disruption. Alfa Laval specialists can replace your equipment with identical units or help you find the correct contact person who can help address your specific needs.

#### *Monitoring*

Equipment must be monitored on a regular basis. Selfinspection can be done on site, without the supervision of Alfa Laval staff. Visually inspect the units and listen for any signs of mechanical wear, deposits, need for degreasing, and frost buildup at least once a month. Perform cleaning accordingly.

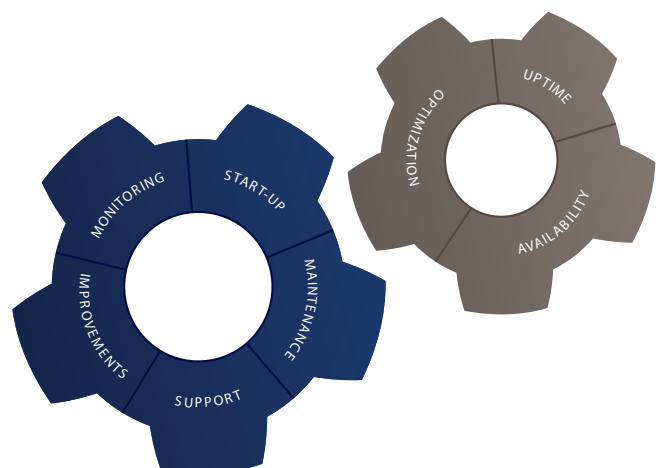



# Spare parts

Spare parts can be selected and ordered in the online eBusiness tool Alfa Laval Anytime. Our spare parts finder tool for easy finding of the spare parts codes can be downloaded from Anytime. Always use latest version for up-to-date item codes.

If required please contact your local Alfa Laval Representative for assistance.

**Spare parts Optigo CS**

1	Fan motors
2	Electrical defrost heater KIT
3	Drip tray drain

Alfa Laval instruction manuals give detailed information for maintenance of air coolers including replacement of fan motors and electrical heaters. Instruction manuals can be downloaded at the link in the QR code.



Alfa Laval Anytime

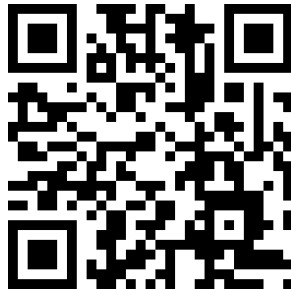

Instruction manuals

**CS200**



**CS300**

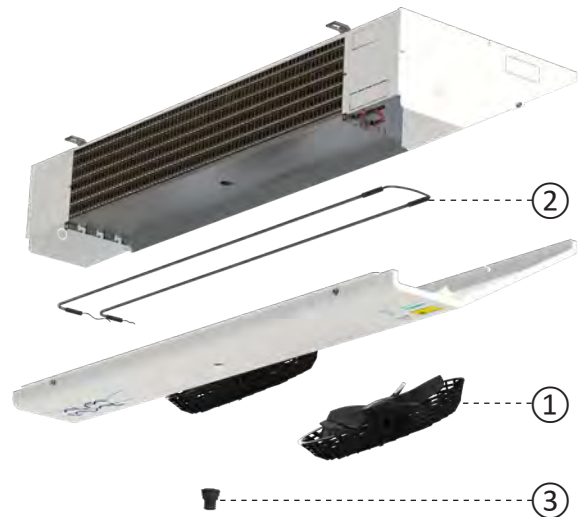

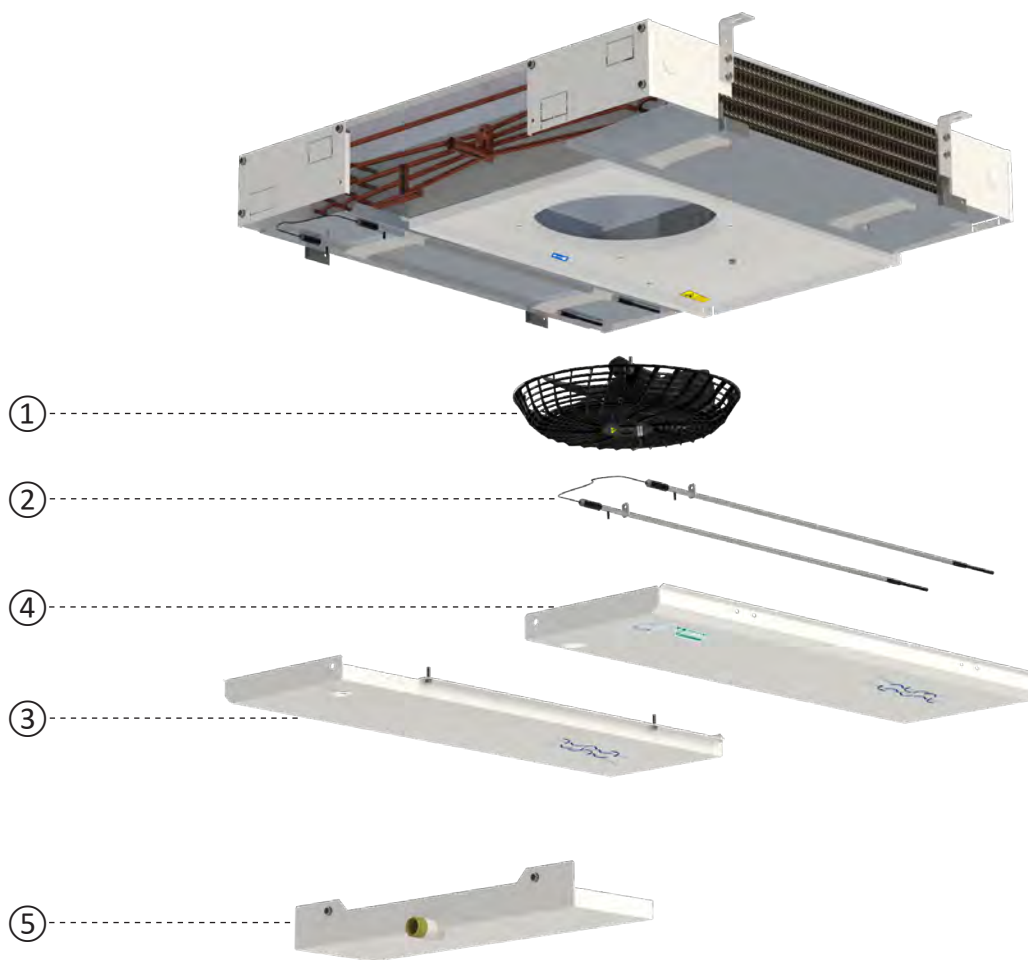

**Spare parts Optigo CD**

1 Fan motors

2 Defrost heater kits (all heaters, conn. box & fixing materials)

3 Drip tray left

4 Drip tray right

5 Drip tray central

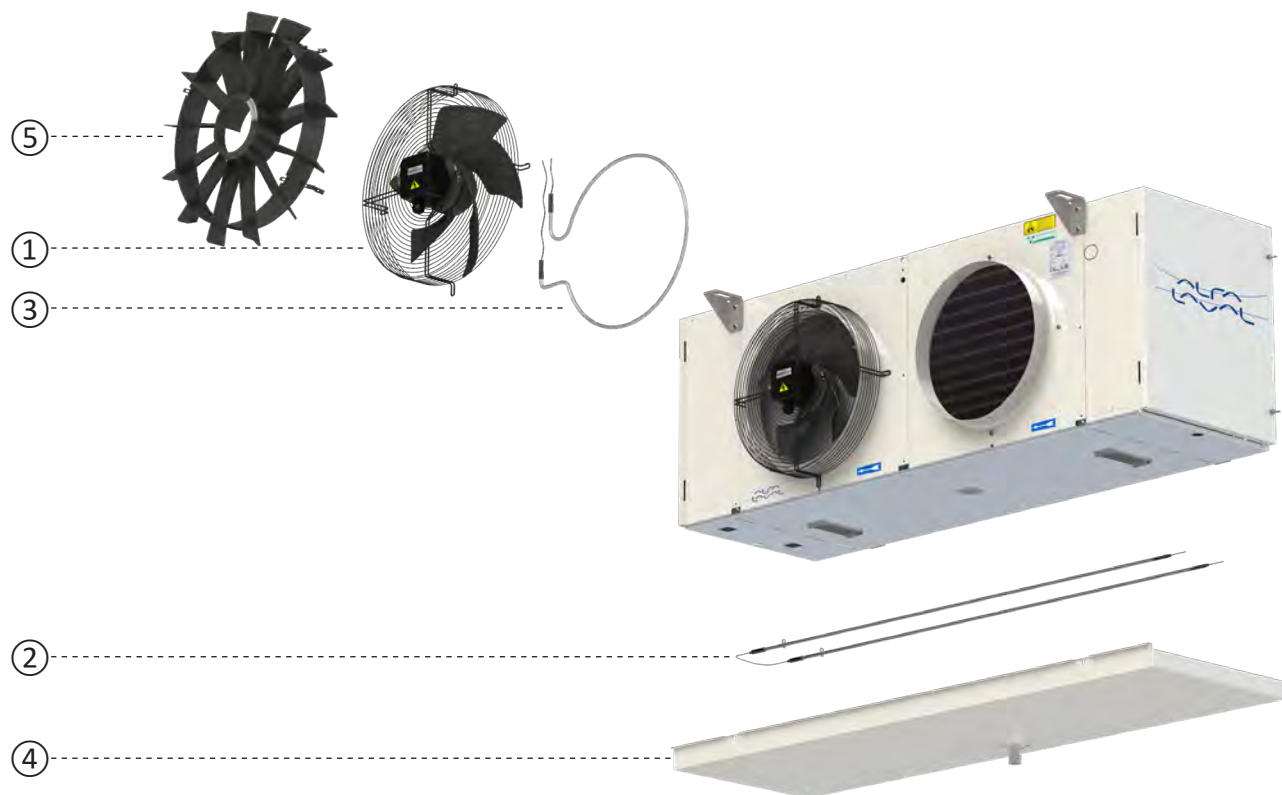

**Spare parts Optigo CC**

1	Fan motors
2	Electrical defrost heaters (coil & drip tray heater identical)
2	Electrical defrost kits (heaters, conn. box & fixing materials)
3	Fan ring heaters
3	Fan ring heater kits (heaters, connection box & fixing materials)
4	Drip tray
5	Air streamer (draw-through models only)



### Spare parts AlfaBlue Junior

1 End cover - bend side

2 End cover - connection side

3 Mounting profiles (horizontal airflow)

4 Mounting feet (vertical airflow)

5 Fan

6 Vibration damper

- Pressure sensor for FP

- Temperature sensor for FT

7 Switch on/off



## Quick selection tables

### Cooling capacities condensers

Cooling capacities as given in the tables are nominal capacities in compliance with Eurovent regulations and EN327.

Standard Condition	Air inlet temp. (°C)	Condensing temp. (°C)	Superheating (K)
SC15	25	40	25

In addition to the Eurovent Standard Condition, the tables also show capacity values for  $T_{\text{air-on}} +25\text{ °C}$  and  $T_{\text{cond.}} +40\text{ °C}$  and SH 35 K.

All nominal capacities are calculated with R404A.

To get capacity with other refrigerants, multiply by the following correction factors R404A capacity in the same condition:

Refrigerant	Correction factor SC15 (dew-point)
R507A	1.00
R134a	0.96
R513A	0.94
R450A	0.89
R407F	0.89
R407A	0.89

### Cooling capacities air coolers

Cooling capacities as given in the tables are nominal capacities for wet conditions ( $Q_n$ ) in compliance with Eurovent regulations and EN328. These nominal values have been calculated from the standard (dry) condition  $Q_{\text{St}}$  with the following formula:  $Q_n = Q_{\text{St}} \times \text{correction factor}$ .

Standard Condition	Air inlet temp. (°C)	Evaporating temp. (°C)	Relative humidity	Correction factor
SC1	10	0	85%	1.35
SC2	0	-8	85%	1.15
SC3	-18	-25	95%	1.05
SC4	-25	-31	95%	1.01

In addition to the Eurovent Standard Conditions, the tables also show DT1 capacity values for  $T_{\text{air-on}} +2\text{ °C}$  and  $T_{\text{evap.}} -8\text{ °C}$  at RH 85%.

All nominal capacities are calculated with R404A.

To get capacity with other refrigerants, multiply by the following correction factors R404A capacity in the same condition:

Refrigerant	Correction factors (dew-point)				
	DT1 +2/-8 °C	SC1	SC2	SC3	SC4
R407A	1.22	1.19	1.24	1.28	1.32
R407F	1.22	1.19	1.24	1.29	1.35
R507A	0.97	0.97	0.97	0.97	0.97
R134a	0.92	0.93	0.91	0.85	-
R450A	1.11	1.10	1.12	1.13	1.15
R513A	0.91	0.91	0.91	0.85	-

### High-glide refrigerants

Many of the new refrigerants which have recently been introduced on the market are blends. Some of these blends show a considerable change in temperature while condensing or evaporating, called *glide*. The glide is the temperature change between bubble-point and dew-point (at constant pressure).

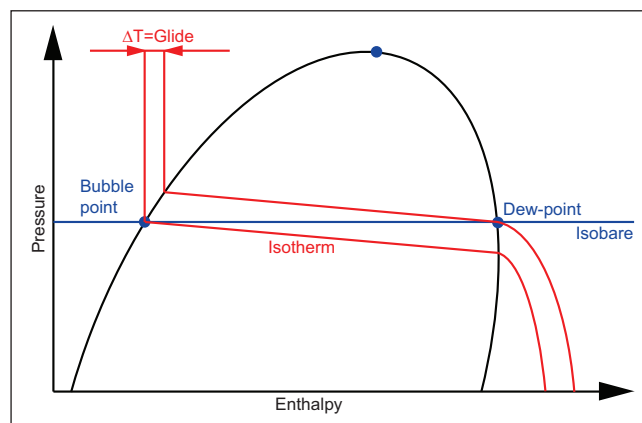

Glide is caused by the variable composition of the refrigerant during condensation or evaporation:

- During evaporation the most volatile component changes to vapor first, while the boiling temperature rises, until the the least volatile components evaporate and no liquid is left at the so-called dew-point.
- During condensation the least volatile component condenses first at dew-point, while temperature decreases, until the most volatile components condensate and no vapor is left at the so-called bubble-point.



### High glide refrigerants and condensers

Traditional condenser design is based on condensing temperature being the refrigerant dew-point temperature and the compressor discharge pressure is taken as condensing pressure. This worked fine as long as azeotropic or nearly-azeotropic refrigerants were used.

With high glide refrigerants, a design based on the dew-point approach, results in oversized units.

The concept of **mean condensing temperature** defined as the mean between dew-point and bubble-point temperature has been then introduced. A design based on the mean-temperature approach results in the same condenser size compared to azeotropic (glide-free) refrigerants.

Nevertheless it has to be considered that mean-temperature approach comes with higher condensing pressures.

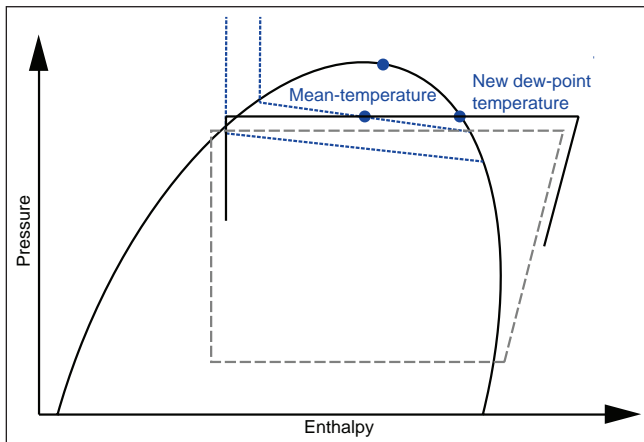

To get capacity with high glide refrigerants, **multiply by the following correction factors R404A capacity in the same condition:**

Refrigerant	Correction factors SC15	
	Mean-temperature	Dew-point
R452A	1.02	0.93
R455A	1.01	0.64
R449A	0.99	0.89
R448A	0.99	0.89

### High glide refrigerants and air coolers

Traditional air cooler design is based on evaporating temperature being the refrigerant dew-point temperature at the evaporating pressure. Glide boosts the evaporator's performance thus allowing its size to be reduced. If the size is reduced, there is the chance to reduce the cost of the cooler.

Mean-temperature approach is applicable also to evaporators design and is the advised approach for unpacked food applications, for which dew-point approach may result in higher dehumidification and consequent higher weight losses of the products stored.

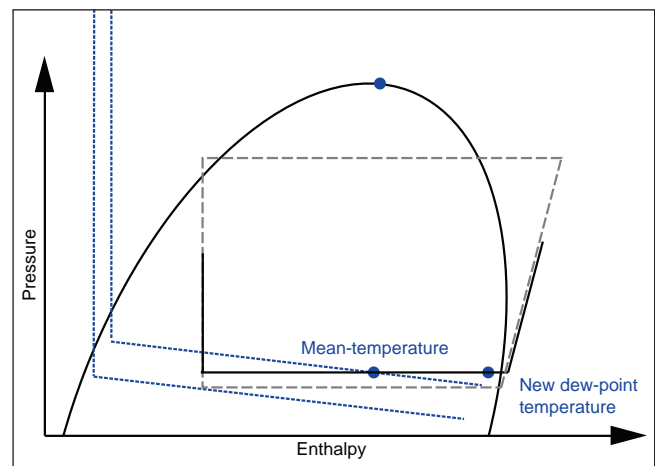

To get capacity with high glide refrigerants, **R404A capacity in the same condition is to be multiplied by the following correction factors:**

Refrigerant	Correction factors for dew-point selection				
	DT1 +2/-8 °C	SC1	SC2	SC3	SC4
R455A	1.22	1.19	1.24	1.29	1.35
R448A	1.24	1.23	1.26	1.28	1.31
R449A	1.22	1.21	1.23	1.24	1.26
R452A	0.92	0.92	0.91	0.84	-

Refrigerant	Correction factors for mean temperature selection				
	DT1 +2/-8 °C	SC1	SC2	SC3	SC4
R448A	0.92	0.91	0.89	0.87	0.85
R449A	0.92	0.91	0.89	0.87	0.85
R452A	0.93	0.92	0.91	0.89	0.87
R455A	0.90	0.89	0.85	0.82	0.78



### Air throw

The values given in the tables are for ceiling mounted coolers at  $t=20\text{ }^{\circ}\text{C}$ , an unrestrained air flow in the cold room and a minimal air velocity of  $0.25\text{ m/s}$  at the given air throw distance. The height and air circulation of the room may influence the air throw.



### Sound pressure dB(A)

Sound pressure as given in the tables are sound pressure levels in dB(A) in free field conditions according to EN13487, at 3 m distance for Optigo range and 10 m distance for AlfaBlue Junior range. Values may deviate depending on situations at site.

### Stock units

A selection of models is available from stock for all the three Optigo lines (CS, CD, CC) for fast delivery. In the selection tables stock units are highlighted with bold text and a tick in the column "stock article".

Model	Nominal capacities HFC DX					EC Fans						Connections		Stock model	
	DT1 +2/-8 °C	SC1	SC2	SC3	SC4	operating power nr.	air throw W	sound pressure m	air flow dB(A)	air flow m <sup>3</sup> /h	coil surface m <sup>2</sup>	Int. volume dm <sup>3</sup>	in mm		out mm
CSE	kW	kW	kW	kW	kW										
Fin spacing 4 mm, fan speed H															
CSEH201 B 4	1.1	1.3	0.9			1	33	5.7	43	515	2.8	0.4	12	12	✓
CSEH202 B 4	2.2	2.6	1.8			2	66	8.0	46	1030	5.6	0.8	12	12	✓
CSEH301 B 4	1.8	2.1	1.4			1	35	6.5	42	763	4.7	0.7	12	12	✓
CSEH301 C 4	2.2	2.5	1.7			1	35	5.7	42	667	7.0	1.1	12	12	✓
CSEH302 B 4	3.4	3.9	2.7			2	70	9.2	45	1525	9.4	1.3	12	14	✓
CSEH302 C 4	4.4	5.0	3.4			2	70	8.0	45	1334	14.0	1.9	16	16	✓
CSEH303 B 4	5.5	6.2	4.3			3	105	11.3	47	2287	14.0	1.8	16	16	✓
CSEH303 C 4	6.1	7.0	4.8			3	105	9.8	47	2002	21.1	2.7	16	18	✓
CSEH304 C 4	8.4	9.6	6.6			4	140	11.4	48	2669	28.1	3.5	16	20	✓
Fin spacing 4 mm, fan speed L															
CSEL201 B 4	1.0	1.1	0.8			1	19	4.2	37	378	2.8	0.4	12	12	-
CSEL202 B 4	1.9	2.2	1.5			2	38	5.9	40	755	5.6	0.8	12	12	-
CSEL301 B 4	1.5	1.7	1.2			1	17	4.5	33	531	4.7	0.7	12	12	-
CSEL301 C 4	1.7	2.0	1.3			1	17	4.0	33	468	7.0	1.1	12	12	-
CSEL302 B 4	2.8	3.2	2.2			2	34	6.4	36	1061	9.4	1.3	12	14	-
CSEL302 C 4	3.5	3.9	2.7			2	34	5.6	36	937	14.0	1.9	16	16	-
CSEL303 B 4	4.5	5.1	3.5			3	51	7.8	38	1592	14.0	1.8	16	16	-
CSEL303 C 4	5.0	5.7	3.9			3	51	6.9	38	1405	21.1	2.7	16	18	-
CSEL304 C 4	6.8	7.7	5.3			4	68	8.0	39	1873	28.1	3.5	16	20	-
Fin spacing 7mm, fan speed H															
CSEH201 B 7	0.8		0.7	0.5	0.4	1	33	6.2	43	559	1.7	0.4	12	12	✓
CSEH202 B 7	1.7		1.3	1.0	0.8	2	66	8.7	46	1119	3.4	0.8	12	12	✓
CSEH301 B 7	1.3		1.0	0.8	0.6	1	35	7.2	42	848	2.8	0.7	12	12	-
CSEH301 C 7	1.7		1.3	1.0	0.8	1	35	6.5	42	762	4.2	1.1	12	12	✓
CSEH302 B 7	2.6		2.0	1.5	1.2	2	70	10.2	45	1696	5.6	1.3	12	14	✓
CSEH302 C 7	3.5		2.7	2.0	1.6	2	70	9.2	45	1523	8.5	1.9	16	16	✓
CSEH303 B 7	4.0		3.1	2.3	1.9	3	105	12.5	47	2544	8.5	1.8	16	16	✓
CSEH303 C 7	5.0		3.9	2.9	2.3	3	105	11.2	47	2285	12.7	2.7	16	18	✓
CSEH304 C 7	6.8		5.3	3.9	3.2	4	140	13.0	48	3047	16.9	3.5	16	20	✓
CSEH305 C 7	8.1		6.4	4.7	3.8	5	175	14.5	49	3808	21.1	4.4	16	22	✓
Fin spacing 7 mm, fan speed L															
CSEL201 B 7	0.7		0.6	0.4	0.3	1	19	4.5	37	413	1.7	0.4	12	12	-
CSEL202 B 7	1.4		1.1	0.8	0.7	2	38	6.4	40	825	3.4	0.8	12	12	-
CSEL301 B 7	1.1		0.9	0.6	0.5	1	17	5.0	33	587	2.8	0.7	12	12	-
CSEL301 C 7	1.4		1.1	0.8	0.7	1	17	4.5	33	534	4.2	1.1	12	12	-
CSEL302 B 7	2.1		1.7	1.2	1.0	2	34	7.1	36	1175	5.6	1.3	12	14	-
CSEL302 C 7	2.8		2.2	1.6	1.3	2	34	6.4	36	1067	8.5	1.9	16	16	-
CSEL303 B 7	3.3		2.6	1.9	1.5	3	51	8.7	38	1762	8.5	1.8	16	16	-
CSEL303 C 7	4.1		3.2	2.3	1.9	3	51	7.9	38	1600	12.7	2.7	16	18	-
CSEL304 C 7	5.5		4.3	3.1	2.6	4	68	9.1	39	2134	16.9	3.5	16	20	-
CSEL305 C 7	6.7		5.3	3.8	3.1	5	85	10.2	40	2667	21.1	4.4	16	22	-



Model	Nominal capacities CO <sub>2</sub> DX				EC Fans							Connections		Stock model
	DT1 +2/-8 °C	SC2	SC3	SC4	operating power nr.	air throw W	sound pressure m	air flow dB(A)	air flow m <sup>3</sup> /h	coil surface m <sup>2</sup>	Int. volume dm <sup>3</sup>	in mm	out mm	
<b>CSX</b>														
Fin spacing 7mm. fan speed H														
CSXH201 B 7	0.9	0.7	0.5	0.4	1	33	6.2	43	559	1.7	0.4	12	12	✓
CSXH301 C 7	1.8	1.4	1.0	0.8	1	35	6.5	42	762	4.2	0.9	12	12	✓
CSXH302 C 7	3.5	2.7	2.0	1.7	2	70	9.2	45	1523	8.5	1.6	12	14	✓
CSXH303 C 7	5.2	4.1	3.0	2.5	3	105	11.2	47	2285	12.7	2.3	12	14	✓
CSXH304 C 7	7.1	5.5	4.1	3.4	4	140	13.0	48	3047	16.9	3.0	12	14	✓
CSXH305 C 7	8.8	6.9	5.1	4.2	5	175	14.5	49	3808	21.1	3.7	12	14	✓
Fin spacing 7 mm. fan speed L														
CSXL201 B 7	0.7	0.6	0.4	0.3	1	19	4.5	37	413	1.7	0.4	12	12	-
CSXL301 C 7	1.4	1.1	0.8	0.6	1	17	4.5	33	534	4.2	0.9	12	12	-
CSXL302 C 7	2.8	2.2	1.6	1.3	2	34	6.4	36	1067	8.5	1.6	12	14	-
CSXL303 C 7	4.2	3.3	2.4	2.0	3	51	7.9	38	1600	12.7	2.3	12	14	-
CSXL304 C 7	5.7	4.4	3.2	2.6	4	68	9.1	39	2134	16.9	3.0	12	14	-
CSXL305 C 7	7.1	5.5	4.0	3.3	5	85	10.2	40	2667	21.1	3.7	12	14	-

Model	Nominal capacities HFC DX			AC fans 230/50/1							Connections		Stock model
	DT1 +2/-8 °C kW	SC1 kW	SC2 kW	fan power nr.	air throw W	sound pressure dB(A)	air flow m <sup>3</sup> /h	coil surface m <sup>2</sup>	Int. volume dm <sup>3</sup>	OD in mm	OD out mm		
Fin spacing 4 mm, fan speed H													
CDEH301 B 4	2.4	2.6	1.8	1	72	5.7	42	1177	7.1	1.5	12	16	-
CDEH301 C 4	3.0	3.3	2.2	1	72	5.2	42	1067	10.7	2.3	12	16	-
CDEH302 B 4	4.8	5.2	3.5	2	144	8.1	45	2332	13.9	2.7	16	16	-
CDEH302 C 4	5.9	6.4	4.4	2	144	7.3	45	2107	20.8	4.0	16	22	-
CDEH303 B 4	7.3	7.9	5.4	3	216	9.9	47	3486	20.6	3.8	16	22	-
CDEH303 C 4	8.7	9.6	6.5	3	216	9.0	47	3147	30.9	5.7	16	22	-
CDEH304 B 4	9.5	10.5	7.1	4	288	11.5	48	4641	27.3	5.0	16	22	-
CDEH304 C 4	10.9	12.4	8.3	4	288	10.3	48	4187	41.0	7.5	16	22	-
CDEH401 B 4	5.7	6.5	4.3	1	210	7.8	51	2656	19.0	3.9	14	14	-
CDEH401 C 4	7.6	8.3	5.6	1	210	7.4	51	2526	28.5	5.9	16	16	-
CDEH402 B 4	11.5	13.0	8.7	2	420	11.0	54	5311	38.0	7.2	16	28	-
CDEH402 C 4	15.2	16.6	11.3	2	420	10.5	54	5052	56.9	10.9	16	35	-
CDEH403 B 4	18.2	20.1	13.5	3	630	13.5	56	7967	56.9	10.5	16	35	-
CDEH403 C 4	21.4	24.1	16.2	3	630	12.8	56	7579	85.4	15.8	22	35	-
Fin spacing 4 mm, fan speed L													
CDEL401 B 4	4.9	5.5	3.7	1	140	5.8	41	1991	19.0	3.9	14	14	-
CDEL401 C 4	6.1	6.7	4.6	1	140	5.5	41	1868	28.5	5.9	16	16	-
CDEL402 B 4	9.8	10.9	7.4	2	280	8.3	44	3981	38.0	7.2	16	28	-
CDEL402 C 4	12.3	13.4	9.1	2	280	7.8	44	3735	56.9	10.9	16	35	-
CDEL403 B 4	15.2	16.7	11.3	3	420	10.1	46	5972	56.9	10.5	16	35	-
CDEL403 C 4	17.7	19.7	13.4	3	420	9.5	46	5603	85.4	15.8	22	35	-

Model	Nominal capacities HFC DX			AC fans 230/50/1							Connections		Stock model
	DT1 +2/-8 °C kW	SC2 kW	SC3 kW	fan power nr.	air throw W	sound pressure dB(A)	air flow m <sup>3</sup> /h	coil surface m <sup>2</sup>	Int. volume dm <sup>3</sup>	OD in mm	OD out mm		
Fin spacing 5.5 mm, fan speed H													
CDEH301 B 5.5	2.1	1.5	1.2	1	72	5.9	42	1216	5.3	1.5	12	16	-
CDEH301 C 5.5	2.7	2.0	1.6	1	72	5.4	42	1118	8.0	2.3	12	16	-
CDEH302 B 5.5	4.1	3.0	2.3	2	144	8.4	45	2411	10.4	2.7	16	16	✓
CDEH302 C 5.5	5.3	3.9	3.1	2	144	7.7	45	2210	15.6	4.0	16	22	-
CDEH303 B 5.5	6.3	4.6	3.6	3	216	10.3	47	3606	15.4	3.8	16	22	✓
CDEH303 C 5.5	7.8	5.8	4.5	3	216	9.4	47	3302	23.2	5.7	16	22	-
CDEH304 B 5.5	8.3	6.1	4.8	4	288	11.9	48	4802	20.5	5.0	16	22	✓
CDEH304 C 5.5	10.0	7.5	5.7	4	288	10.9	48	4394	30.7	7.5	16	22	✓
CDEH401 B 5.5	5.0	3.7	2.9	1	210	7.9	51	2703	14.2	3.9	14	14	-
CDEH401 C 5.5	6.7	5.0	3.9	1	210	7.6	51	2589	21.4	5.9	16	16	-
CDEH402 B 5.5	10.0	7.5	5.8	2	420	11.2	54	5407	28.5	7.2	16	28	-
CDEH402 C 5.5	13.4	9.9	7.9	2	420	10.7	54	5178	42.7	10.9	16	35	-
CDEH403 B 5.5	15.5	11.5	9.0	3	630	13.7	56	8110	42.7	10.5	16	35	-
CDEH403 C 5.5	19.2	14.5	11.1	3	630	13.2	56	7766	64.1	15.8	22	35	-
Fin spacing 5.5 mm, fan speed L													
CDEL401 B 5.5	4.2	3.2	2.4	1	140	6.0	41	2039	14.2	3.9	14	14	-
CDEL401 C 5.5	5.4	4.0	3.2	1	140	5.7	41	1931	21.4	5.9	16	16	-
CDEL402 B 5.5	8.4	6.3	4.9	2	280	8.5	44	4079	28.5	7.2	16	28	-
CDEL402 C 5.5	10.9	8.1	6.4	2	280	8.0	44	3862	42.7	10.9	16	35	-
CDEL403 B 5.5	12.9	9.6	7.6	3	420	10.4	46	6118	42.7	10.5	16	35	-
CDEL403 C 5.5	15.9	11.9	9.3	3	420	9.8	46	5793	64.1	15.8	22	35	-

Model	Nominal capacities HFC DX				AC fans 230/50/1							Connections		Stock model
	DT1 +2/-8 °C	SC2	SC3	SC4	fan power nr.	air throw W	sound pressure dB(A)	air flow m <sup>3</sup> /h	coil surface m <sup>2</sup>	Int. volume dm <sup>3</sup>	OD in mm	OD out mm		
CDE	kW	kW	kW	kW										
Fin spacing 7 mm, fan speed H														
CDEH301 B 7	<b>1.8</b>	1.3	1.0	0.9	1	72	6.1	42	1251	4.3	1.5	12	16	-
CDEH301 C 7	<b>2.4</b>	1.8	1.4	1.2	1	72	5.6	42	1163	6.5	2.3	12	16	-
CDEH302 B 7	<b>3.6</b>	2.6	2.1	1.7	2	144	8.6	45	2484	8.4	2.7	16	16	-
CDEH302 C 7	<b>4.8</b>	3.5	2.8	2.3	2	144	8.0	45	2302	12.6	4.0	16	22	-
CDEH303 B 7	<b>5.5</b>	4.0	3.2	2.6	3	216	10.6	47	3716	12.5	3.8	16	22	-
CDEH303 C 7	<b>7.1</b>	5.3	4.1	3.4	3	216	9.8	47	3441	18.8	5.7	16	22	-
CDEH304 B 7	<b>7.3</b>	5.4	4.2	3.4	4	288	12.2	48	4949	16.6	5.0	16	22	-
CDEH304 C 7	<b>9.1</b>	6.9	5.3	4.2	4	288	11.3	48	4581	24.9	7.5	16	22	-
CDEH401 B 7	<b>4.4</b>	3.3	2.6	2.0	1	210	8.1	51	2744	11.5	3.9	14	14	-
CDEH401 C 7	<b>6.0</b>	4.4	3.5	2.9	1	210	7.8	51	2642	17.3	5.9	16	16	-
CDEH402 B 7	<b>8.8</b>	6.6	5.1	4.1	2	420	11.4	54	5487	23.1	7.2	16	28	-
CDEH402 C 7	<b>11.9</b>	8.9	7.0	5.8	2	420	11.0	54	5283	34.6	10.9	16	35	-
CDEH403 B 7	<b>13.6</b>	10.1	7.9	6.5	3	630	14.0	56	8231	34.6	10.5	16	35	-
CDEH403 C 7	<b>17.4</b>	13.0	10.1	8.1	3	630	13.4	56	7925	51.9	15.8	22	35	-
Fin spacing 7 mm, fan speed L														
CDEL401 B 7	<b>3.7</b>	2.8	2.2	1.8	1	140	6.1	41	2078	11.5	3.9	14	14	-
CDEL401 C 7	<b>4.9</b>	3.6	2.9	2.4	1	140	5.8	41	1981	17.3	5.9	16	16	-
CDEL402 B 7	<b>7.4</b>	5.5	4.3	3.5	2	280	8.6	44	4155	23.1	7.2	16	28	-
CDEL402 C 7	<b>9.8</b>	7.2	5.8	4.8	2	280	8.2	44	3962	34.6	10.9	16	35	-
CDEL403 B 7	<b>11.3</b>	8.4	6.6	5.4	3	420	10.6	46	6233	34.6	10.5	16	35	-
CDEL403 C 7	<b>14.4</b>	10.8	8.5	6.9	3	420	10.1	46	5942	51.9	15.8	22	35	-

Model	Nominal capacities HFC DX			EC fans 230/50-60/1							Connections		Stock model
	DT1 +2/-8 °C	SC1	SC2	operating power nr.	air throw W	sound pressure dB(A)	air flow m <sup>3</sup> /h	coil surface m <sup>2</sup>	Int. volume dm <sup>3</sup>	in mm	out mm		
CDE	kW	kW	kW										
Fin spacing 4 mm, fan speed H													
CDEHE301 B 4	2.0	2.2	1.5	1	35	4.3	42	881	7.1	1.5	12	16	-
CDEHE301 C 4	2.4	2.7	1.8	1	35	3.9	42	799	10.7	2.3	12	16	-
CDEHE302 B 4	4.0	4.3	2.9	2	70	6.1	45	1745	13.9	2.7	16	16	-
CDEHE302 C 4	4.8	5.2	3.6	2	70	5.5	45	1577	20.8	4.0	16	22	-
CDEHE303 B 4	6.0	6.6	4.5	3	105	7.4	47	2608	20.6	3.8	16	22	✓
CDEHE303 C 4	7.1	7.8	5.3	3	105	6.7	47	2356	30.9	5.7	16	22	-
CDEHE304 B 4	8.0	8.8	5.9	4	140	8.6	48	3472	27.3	5.0	16	22	-
CDEHE304 C 4	9.2	10.2	6.9	4	140	7.7	48	3134	41.0	7.5	16	22	✓
CDEHE401 B 4	5.7	6.5	4.3	1	140	7.8	48	2656	19.0	3.9	14	14	-
CDEHE401 C 4	7.6	8.3	5.6	1	140	7.4	48	2526	28.5	5.9	16	16	-
CDEHE402 B 4	11.5	13.0	8.7	2	280	11.0	51	5311	38.0	7.2	16	28	-
CDEHE402 C 4	15.2	16.6	11.3	2	280	10.5	51	5052	56.9	10.9	16	35	-
CDEHE403 B 4	18.2	20.1	13.5	3	420	13.5	53	7967	56.9	10.5	16	35	-
CDEHE403 C 4	21.4	24.1	16.2	3	420	12.8	53	7579	85.4	15.8	22	35	-
Fin spacing 4 mm, fan speed L													
CDELE301 B 4	1.6	1.7	1.1	1	17	2.9	33	606	7.1	1.5	12	16	-
CDELE301 C 4	1.9	2.0	1.4	1	17	2.7	33	555	10.7	2.3	12	16	-
CDELE302 B 4	3.1	3.3	2.3	2	34	4.2	36	1201	13.9	2.7	16	16	-
CDELE302 C 4	3.7	4.0	2.7	2	34	3.8	36	1097	20.8	4.0	16	22	-
CDELE303 B 4	4.7	5.1	3.5	3	51	5.1	38	1796	20.6	3.8	16	22	-
CDELE303 C 4	5.5	6.0	4.1	3	51	4.7	38	1639	30.9	5.7	16	22	-
CDELE304 B 4	6.3	6.9	4.7	4	68	5.9	39	2391	27.3	5.0	16	22	-
CDELE304 C 4	7.2	7.9	5.4	4	68	5.4	39	2181	41.0	7.5	16	22	-
CDELE401 B 4	4.9	5.5	3.7	1	73	5.8	41	1991	19.0	3.9	14	14	-
CDELE401 C 4	6.1	6.7	4.6	1	73	5.5	41	1868	28.5	5.9	16	16	-
CDELE402 B 4	9.8	10.9	7.4	2	146	8.3	44	3981	38.0	7.2	16	28	-
CDELE402 C 4	12.3	13.4	9.1	2	146	7.8	44	3735	56.9	10.9	16	35	-
CDELE403 B 4	15.2	16.7	11.3	3	219	10.1	46	5972	56.9	10.5	16	35	-
CDELE403 C 4	17.7	19.7	13.4	3	219	9.5	46	5603	85.4	15.8	22	35	-

Model	Nominal capacities HFC DX			EC fans 230/50-60/1							Connections		Stock model
	DT1 +2/-8 °C	SC2	SC3	operating power nr.	air throw W	sound pressure dB(A)	air flow m <sup>3</sup> /h	coil surface m <sup>2</sup>	Int. volume dm <sup>3</sup>	in mm	out mm		
CDE	kW	kW	kW										
Fin spacing 5.5 mm, fan speed H													
CDEHE301 B 5.5	1.7	1.3	1.0	1	35	4.4	42	913	5.3	1.5	12	16	-
CDEHE301 C 5.5	2.2	1.6	1.3	1	35	4.1	42	839	8.0	2.3	12	16	-
CDEHE302 B 5.5	3.4	2.5	1.9	2	70	6.3	45	1810	10.4	2.7	16	16	-
CDEHE302 C 5.5	4.3	3.2	2.5	2	70	5.8	45	1659	15.6	4.0	16	22	✓
CDEHE303 B 5.5	5.2	3.8	3.0	3	105	7.7	47	2708	15.4	3.8	16	22	-
CDEHE303 C 5.5	6.4	4.8	3.8	3	105	7.1	47	2478	23.2	5.7	16	22	-
CDEHE304 B 5.5	6.9	5.1	4.0	4	140	8.9	48	3605	20.5	5.0	16	22	-
CDEHE304 C 5.5	8.3	6.2	4.8	4	140	8.1	48	3297	30.7	7.5	16	22	✓
CDEHE401 B 5.5	5.0	3.7	2.9	1	140	7.9	48	2703	14.2	3.9	14	14	-
CDEHE401 C 5.5	6.7	5.0	3.9	1	140	7.6	48	2589	21.4	5.9	16	16	-
CDEHE402 B 5.5	10.0	7.5	5.8	2	280	11.2	51	5407	28.5	7.2	16	28	-
CDEHE402 C 5.5	13.4	9.9	7.9	2	280	10.7	51	5178	42.7	10.9	16	35	-
CDEHE403 B 5.5	15.5	11.5	9.0	3	420	13.7	53	8110	42.7	10.5	16	35	-
CDEHE403 C 5.5	19.2	14.5	11.1	3	420	13.2	53	7766	64.1	15.8	22	35	-
Fin spacing 5.5 mm, fan speed L													
CDELE301 B 5.5	1.3	1.0	0.8	1	17	3.0	33	627	5.3	1.5	12	16	-
CDELE301 C 5.5	1.7	1.2	1.0	1	17	2.8	33	581.9	8.0	2.3	12	16	-
CDELE302 B 5.5	2.6	1.9	1.5	2	34	4.3	36	1245	10.4	2.7	16	16	-
CDELE302 C 5.5	3.3	2.4	1.9	2	34	4.0	36	1152	15.6	4	16	22	-
CDELE303 B 5.5	4.0	3.0	2.3	3	51	5.3	38	1862	15.4	3.8	16	22	-
CDELE303 C 5.5	4.9	3.7	2.9	3	51	4.9	38	1722	23.2	5.7	16	22	-
CDELE304 B 5.5	5.4	4.0	3.2	4	68	6.1	39	2480	20.5	5	16	22	-
CDELE304 C 5.5	6.5	4.8	3.8	4	68	5.7	39	2292	30.7	7.5	16	22	-
CDELE401 B 5.5	4.2	3.2	2.4	1	73	6.0	41	2039	14.2	3.9	14	14	-
CDELE401 C 5.5	5.4	4.0	3.2	1	73	5.7	41	1931	21.4	5.9	16	16	-
CDELE402 B 5.5	8.4	6.3	4.9	2	146	8.5	44	4079	28.5	7.2	16	28	-
CDELE402 C 5.5	10.9	8.1	6.4	2	146	8.0	44	3862	42.7	10.9	16	35	-
CDELE403 B 5.5	12.9	9.6	7.6	3	219	10.4	46	6118	42.7	10.5	16	35	-
CDELE403 C 5.5	15.9	11.9	9.3	3	219	9.8	46	5793	64.1	15.8	22	35	-

Model	Nominal capacities HFC DX				EC fans 230/50-60/1							Connections		Stock model
	DT1 +2/-8 °C	SC2	SC3	SC4	operating power nr.	air throw W	sound pressure dB(A)	air flow m <sup>3</sup> /h	coil surface m <sup>2</sup>	Int. volume dm <sup>3</sup>	OD in mm	OD out mm		
CDE	kW	kW	kW	kW										
Fin spacing 7 mm, fan speed H														
CDEHE301 B 7	1.5	1.1	0.9	0.7	1	35	4.5	42	939	4.3	1.5	12	16	-
CDEHE301 C 7	2.0	1.5	1.2	1.0	1	35	4.2	42	872	6.5	2.3	12	16	-
CDEHE302 B 7	3.0	2.2	1.7	1.4	2	70	6.5	45	1865	8.4	2.7	16	16	-
CDEHE302 C 7	3.9	2.9	2.3	1.9	2	70	6.0	45	1727	12.6	4.0	16	22	-
CDEHE303 B 7	4.6	3.3	2.6	2.2	3	105	7.9	47	2790	12.5	3.8	16	22	-
CDEHE303 C 7	5.8	4.3	3.4	2.8	3	105	7.3	47	2582	18.8	5.7	16	22	-
CDEHE304 B 7	6.1	4.5	3.5	2.9	4	140	9.2	48	3715	16.6	5.0	16	22	-
CDEHE304 C 7	7.6	5.7	4.4	3.6	4	140	8.5	48	3437	24.9	7.5	16	22	-
CDEHE401 B 7	4.4	3.3	2.6	2.0	1	140	8.1	48	2744	11.5	3.9	14	14	-
CDEHE401 C 7	6.0	4.4	3.5	2.9	1	140	7.8	48	2642	17.3	5.9	16	16	-
CDEHE402 B 7	8.8	6.6	5.1	4.1	2	280	11.4	51	5487	23.1	7.2	16	28	-
CDEHE402 C 7	11.9	8.9	7.0	5.8	2	280	11.0	51	5283	34.6	10.9	16	35	-
CDEHE403 B 7	13.6	10.1	7.9	6.5	3	420	14.0	53	8231	34.6	10.5	16	35	-
CDEHE403 C 7	17.4	13.0	10.1	8.1	3	420	13.4	53	7925	51.9	15.8	22	35	-
Fin spacing 7 mm, fan speed L														
CDELE301 B 7	1.2	0.9	0.7	0.6	1	17	3.1	33	643	4.3	1.5	12	16	-
CDELE301 C 7	1.5	1.1	0.9	0.7	1	17	2.9	33	602	6.5	2.3	12	16	-
CDELE302 B 7	2.3	1.7	1.3	1.1	2	34	4.4	36	1278	8.4	2.7	16	16	-
CDELE302 C 7	3.0	2.2	1.8	1.5	2	34	4.1	36	1194	12.6	4.0	16	22	-
CDELE303 B 7	3.5	2.6	2.1	1.7	3	51	5.4	38	1912	12.5	3.8	16	22	-
CDELE303 C 7	4.5	3.3	2.7	2.2	3	51	5.1	38	1786	18.8	5.7	16	22	-
CDELE304 B 7	4.7	3.5	2.8	2.3	4	68	6.3	39	2547	16.6	5.0	16	22	-
CDELE304 C 7	5.9	4.4	3.5	2.9	4	68	5.9	39	2377	24.9	7.5	16	22	-
CDELE401 B 7	3.7	2.8	2.2	1.8	1	73	6.1	41	2078	11.5	3.9	14	14	-
CDELE401 C 7	4.9	3.6	2.9	2.4	1	73	5.8	41	1981	17.3	5.9	16	16	-
CDELE402 B 7	7.4	5.5	4.3	3.5	2	146	8.6	44	4155	23.1	7.2	16	28	-
CDELE402 C 7	9.8	7.2	5.8	4.8	2	146	8.2	44	3962	34.6	10.9	16	35	-
CDELE403 B 7	11.3	8.4	6.6	5.4	3	219	10.6	46	6233	34.6	10.5	16	35	-
CDELE403 C 7	14.4	10.8	8.5	6.9	3	219	10.1	46	5942	51.9	15.8	22	35	-

Model	Nominal capacities CO <sub>2</sub> DX		AC fans 230/50/1							Connections		Stock model
	DT1 +2/-8 °C kW	SC2 kW	fan power nr.	air throw W	sound pressure dB(A)	air flow m <sup>3</sup> /h	coil surface m <sup>2</sup>	Int. volume dm <sup>3</sup>	OD in mm	OD out mm		
Fin spacing 4 mm, fan speed H												
CDXH301 B 4	2.4	1.8	1	72	5.9	42	1224	7.2	0.9	12	12	-
CDXH301 C 4	3.0	2.2	1	72	5.5	42	1127	10.9	1.3	12	12	-
CDXH302 B 4	4.7	3.5	2	144	8.4	45	2429	14.1	1.6	12	12	-
CDXH302 C 4	5.7	4.3	2	144	7.7	45	2230	21.2	2.4	12	12	-
CDXH303 B 4	7.1	5.3	3	216	10.3	47	3634	21.0	2.2	12	12	-
CDXH303 C 4	8.8	6.5	3	216	9.5	47	3332	31.5	3.4	12	12	-
CDXH304 B 4	9.4	7.0	4	288	12.0	48	4839	27.9	2.9	12	12	-
CDXH304 C 4	11.3	8.5	4	288	11.0	48	4434	41.8	4.4	12	12	-
CDXH401 B 4	5.6	4.2	1	210	8.0	51	2710	19.7	2.3	14	14	-
CDXH401 C 4	7.3	5.4	1	210	7.6	51	2596	29.6	3.5	16	16	-
CDXH402 B 4	11.2	8.4	2	420	11.2	54	5419	39.5	4.2	16	16	-
CDXH402 C 4	14.3	10.7	2	420	10.8	54	5192	59.2	6.4	16	16	-
CDXH403 B 4	17.3	12.9	3	630	13.8	56	8129	59.2	6.2	16	16	-
CDXH403 C 4	21.9	16.4	3	630	13.2	56	7788	88.8	9.3	22	22	-
Fin spacing 4 mm, fan speed L												
CDXL401 B 4	4.7	3.6	1	140	6.0	41	2041	19.7	2.3	14	14	-
CDXL401 C 4	6.0	4.4	1	140	5.7	41	1932	29.6	3.5	16	16	-
CDXL402 B 4	9.5	7.1	2	280	8.5	44	4082	39.5	4.2	16	16	-
CDXL402 C 4	11.8	8.8	2	280	8.0	44	3863	59.2	6.4	16	16	-
CDXL403 B 4	14.6	10.9	3	420	10.4	46	6122	59.2	6.2	16	16	-
CDXL403 C 4	17.9	13.4	3	420	9.8	46	5795	88.8	9.3	22	22	-



Model	Nominal capacities CO <sub>2</sub> DX				AC fans 230/50/1							Connections		Stock model
	DT1 +2/-8 °C	SC2	SC3	SC4	fan power nr.	air throw W	sound pressure dB(A)	air flow m <sup>3</sup> /h	coil surface m <sup>2</sup>	Int. volume dm <sup>3</sup>	OD in mm	OD out mm		
CDX	kW	kW	kW	kW										
Fin spacing 7 mm, fan speed H														
CDXH301 B 7	1.8	1.3	1.0	0.8	1	72	6.3	42	1294	4.4	0.9	12	12	-
CDXH301 C 7	2.3	1.7	1.4	1.1	1	72	5.9	42	1217	6.5	1.3	12	12	-
CDXH302 B 7	3.5	2.6	2.0	1.7	2	144	8.9	45	2572	8.5	1.6	12	12	-
CDXH302 C 7	4.5	3.3	2.6	2.1	2	144	8.4	45	2414	12.7	2.4	12	12	-
CDXH303 B 7	5.2	3.8	3.1	2.5	3	216	11.0	47	3850	12.6	2.2	12	12	-
CDXH303 C 7	6.8	5.1	4.0	3.3	3	216	10.3	47	3611	18.9	3.4	12	12	-
CDXH304 B 7	6.9	5.1	4.0	3.3	4	288	12.7	48	5128	16.8	2.9	12	12	-
CDXH304 C 7	8.9	6.6	5.2	4.3	4	288	11.9	48	4808	25.1	4.4	12	12	-
CDXH401 B 7	4.1	3.0	2.4	2.0	1	210	8.2	51	2791	11.9	2.3	14	14	-
CDXH401 C 7	5.5	4.1	3.3	2.7	1	210	7.9	51	2705	17.8	3.5	16	16	-
CDXH402 B 7	8.2	6.1	4.8	3.9	2	420	11.6	54	5583	23.7	4.2	16	16	-
CDXH402 C 7	11.0	8.2	6.5	5.3	2	420	11.2	54	5409	35.6	6.4	16	16	-
CDXH403 B 7	12.4	9.2	7.3	6.0	3	630	14.2	56	8374	35.6	6.2	16	16	-
CDXH403 C 7	16.6	12.4	9.9	8.2	3	630	13.8	56	8114	53.4	9.3	22	22	-
Fin spacing 7 mm, fan speed L														
CDXL401 B 7	3.4	2.6	2.0	1.7	1	140	6.2	41	2123	11.9	2.3	14	14	-
CDXL401 C 7	4.6	3.4	2.7	2.3	1	140	6.0	41	2040	17.8	3.5	16	16	-
CDXL402 B 7	6.9	5.1	4.1	3.3	2	280	8.8	44	4245	23.7	4.2	16	16	-
CDXL402 C 7	9.1	6.8	5.4	4.5	2	280	8.5	44	4081	35.6	6.4	16	16	-
CDXL403 B 7	10.4	7.7	6.2	5.1	3	420	10.8	46	6368	35.6	6.2	16	16	-
CDXL403 C 7	13.7	10.2	8.2	6.8	3	420	10.4	46	6121	53.4	9.3	22	22	-

Model	Nominal capacities CO <sub>2</sub> DX		EC fans 230/50-60/1							Connections		Stock model
	DT1 +2/-8 °C kW	SC2 kW	nr.	operating power W	air throw m	sound pressure dB(A)	air flow m <sup>3</sup> /h	coil surface m <sup>2</sup>	Int. volume dm <sup>3</sup>	in mm	out mm	
Fin spacing 4 mm, fan speed H												
CDXHE301 B 4	2.0	1.5	1	35	4.4	42	916	7.2	0.9	12	12	-
CDXHE301 C 4	2.5	1.8	1	35	4.1	42	842	10.9	1.3	12	12	-
CDXHE302 B 4	4.0	3.0	2	70	6.3	45	1817	14.1	1.6	12	12	-
CDXHE302 C 4	4.7	3.5	2	70	5.8	45	1665	21.2	2.4	12	12	-
CDXHE303 B 4	6.0	4.5	3	105	7.7	47	2718	21.0	2.2	12	12	-
CDXHE303 C 4	7.2	5.4	3	105	7.1	47	2487	31.5	3.4	12	12	-
CDXHE304 B 4	7.9	5.9	4	140	8.9	48	3619	27.9	2.9	12	12	-
CDXHE304 C 4	9.4	7.0	4	140	8.2	48	3310	41.8	4.4	12	12	-
CDXHE401 B 4	5.6	4.2	1	140	8.0	48	2710	19.7	2.3	14	14	-
CDXHE401 C 4	7.3	5.4	1	140	7.6	48	2596	29.6	3.5	16	16	-
CDXHE402 B 4	11.2	8.4	2	280	11.2	51	5419	39.5	4.2	16	16	-
CDXHE402 C 4	14.3	10.7	2	280	10.8	51	5192	59.2	6.4	16	16	-
CDXHE403 B 4	17.3	12.9	3	420	13.8	53	8129	59.2	6.2	16	16	-
CDXHE403 C 4	21.9	16.4	3	420	13.2	53	7788	88.8	9.3	22	22	-
Fin spacing 4 mm, fan speed L												
CDXLE301 B 4	1.6	1.2	1	17	3.0	33	626	7.2	0.9	12	12	-
CDXLE301 C 4	1.9	1.4	1	17	2.8	33	580	10.9	1.3	12	12	-
CDXLE302 B 4	3.1	2.3	2	34	4.3	36	1244	14.1	1.6	12	12	-
CDXLE302 C 4	3.7	2.8	2	34	4.0	36	1149	21.2	2.4	12	12	-
CDXLE303 B 4	4.7	3.5	3	51	5.3	38	1861	21.0	2.2	12	12	-
CDXLE303 C 4	5.6	4.2	3	51	4.9	38	1718	31.5	3.4	12	12	-
CDXLE304 B 4	6.2	4.6	4	68	6.1	39	2478	27.9	2.9	12	12	-
CDXLE304 C 4	7.3	5.5	4	68	5.6	39	2287	41.8	4.4	12	12	-
CDXLE401 B 4	4.7	3.6	1	73	6.0	41	2041	19.7	2.3	14	14	-
CDXLE401 C 4	6.0	4.4	1	73	5.7	41	1932	29.6	3.5	16	16	-
CDXLE402 B 4	9.5	7.1	2	146	8.5	44	4082	39.5	4.2	16	16	-
CDXLE402 C 4	11.8	8.8	2	146	8.0	44	3863	59.2	6.4	16	16	-
CDXLE403 B 4	14.6	10.9	3	219	10.4	46	6122	59.2	6.2	16	16	-
CDXLE403 C 4	17.9	13.4	3	219	9.8	46	5795	88.8	9.3	22	22	-

Model	Nominal capacities CO <sub>2</sub> DX				EC fans 230/50-60/1							Connections		Stock model
	DT1 +2/-8 °C kW	SC2 kW	SC3 kW	SC4 kW	operating power nr.	air throw W	sound pressure m	air flow dB(A)	air flow m <sup>3</sup> /h	coil surface m <sup>2</sup>	Int. volume dm <sup>3</sup>	in mm	out mm	
Fin spacing 7 mm, fan speed H														
CDXHE301 B 7	1.5	1.1	0.8	0.7	1	35	4.7	42	969	4.4	0.9	12	12	-
CDXHE301 C 7	1.9	1.4	1.1	0.9	1	35	4.4	42	914	6.5	1.3	12	12	-
CDXHE302 B 7	2.9	2.2	1.7	1.4	2	70	6.7	45	1927	8.5	1.6	12	12	-
CDXHE302 C 7	3.7	2.8	2.2	1.8	2	70	6.3	45	1812	12.7	2.4	12	12	✓
CDXHE303 B 7	4.3	3.2	2.6	2.0	3	105	8.2	47	2885	12.6	2.2	12	12	-
CDXHE303 C 7	5.7	4.2	3.4	2.8	3	105	7.7	47	2710	18.9	3.4	12	12	✓
CDXHE304 B 7	5.8	4.3	3.4	2.8	4	140	9.5	48	3843	16.8	2.9	12	12	-
CDXHE304 C 7	7.4	5.5	4.4	3.6	4	140	8.9	48	3608	25.1	4.4	12	12	✓
CDXHE401 B 7	4.1	3.0	2.4	2.0	1	140	8.2	48	2791	11.9	2.3	14	14	-
CDXHE401 C 7	5.5	4.1	3.3	2.7	1	140	7.9	48	2705	17.8	3.5	16	16	-
CDXHE402 B 7	8.2	6.1	4.8	3.9	2	280	11.6	51	5583	23.7	4.2	16	16	-
CDXHE402 C 7	11.0	8.2	6.5	5.3	2	280	11.2	51	5409	35.6	6.4	16	16	-
CDXHE403 B 7	12.4	9.2	7.3	6.0	3	420	14.2	53	8374	35.6	6.2	16	16	-
CDXHE403 C 7	16.6	12.4	9.9	8.2	3	420	13.8	53	8114	53.4	9.3	22	22	-
Fin spacing 7 mm, fan speed L														
CDXLE301 B 7	1.1	0.8	0.6	0.5	1	17	3.2	33	662	4.4	0.9	12	12	-
CDXLE301 C 7	1.5	1.1	0.9	0.7	1	17	3.0	33	627	6.5	1.3	12	12	-
CDXLE302 B 7	2.3	1.7	1.3	1.1	2	34	4.6	36	1316	8.5	1.6	12	12	-
CDXLE302 C 7	2.9	2.2	1.7	1.4	2	34	4.3	36	1246	12.7	2.4	12	12	-
CDXLE303 B 7	3.4	2.5	1.9	1.6	3	51	5.6	38	1971	12.6	2.2	12	12	-
CDXLE303 C 7	4.4	3.3	2.6	2.1	3	51	5.3	38	1864	18.9	3.4	12	12	-
CDXLE304 B 7	4.5	3.3	2.7	2.2	4	68	6.5	39	2626	16.8	2.9	12	12	-
CDXLE304 C 7	5.8	4.3	3.4	2.8	4	68	6.1	39	2482	25.1	4.4	12	12	-
CDXLE401 B 7	3.4	2.6	2.0	1.7	1	73	6.2	41	2123	11.9	2.3	14	14	-
CDXLE401 C 7	4.6	3.4	2.7	2.3	1	73	6.0	41	2040	17.8	3.5	16	16	-
CDXLE402 B 7	6.9	5.1	4.1	3.3	2	146	8.8	44	4245	23.7	4.2	16	16	-
CDXLE402 C 7	9.1	6.8	5.4	4.5	2	146	8.5	44	4081	35.6	6.4	16	16	-
CDXLE403 B 7	10.4	7.7	6.2	5.1	3	219	10.8	46	6368	35.6	6.2	16	16	-
CDXLE403 C 7	13.7	10.2	8.2	6.8	3	219	10.4	46	6121	53.4	9.3	22	22	-

Model	Nominal capacities HFC DX			Draw-through AC fans 230/50/1							Connections		Stock model
	DT1 +2/-8 °C kW	SC1 kW	SC2 kW	fan power nr.	air throw W	sound pressure dB(A)	air flow m <sup>3</sup> /h	coil surface m <sup>2</sup>	Int. volume dm <sup>3</sup>	in mm	out mm		
Fin spacing 4 mm, fan speed H													
CCEH251 A 4	2.8	3.1	2.1	1	118	7.8	54	1254	8.4	1.9	12	14	-
CCEH251 B 4	3.5	3.9	2.6	1	118	7.5	54	1200	12.6	2.8	12	16	-
CCEH251 C 4	3.9	4.3	2.9	1	118	7.2	54	1150	16.8	3.7	12	16	-
CCEH252 A 4	5.4	6.1	4.1	2	236	11.3	57	2485	15.9	3.2	12	16	-
CCEH252 B 4	6.6	7.4	5.0	2	236	10.7	57	2371	23.9	4.7	16	18	-
CCEH252 C 4	7.7	8.4	5.8	2	236	10.3	57	2262	31.8	6.3	16	18	-
CCEH253 A 4	7.8	8.8	5.9	3	354	13.9	59	3716	23.4	4.5	16	18	-
CCEH253 B 4	10.3	11.3	7.7	3	354	13.2	59	3539	35.1	6.7	16	22	-
CCEH253 C 4	11.2	12.4	8.4	3	354	12.6	59	3371	46.9	8.9	16	22	-
CCEH254 A 4	11.1	12.2	8.2	4	472	16.1	60	4946	30.9	5.8	16	22	-
CCEH254 B 4	13.2	14.7	9.9	4	472	15.3	60	4707	46.4	8.7	16	22	-
CCEH351 A 4	5.4	6.0	4.0	1	184	13.0	49	2643	13.5	3.0	12	16	-
CCEH351 B 4	6.7	7.4	5.0	1	184	12.2	49	2468	20.2	4.4	16	18	-
CCEH351 C 4	7.5	8.3	5.6	1	184	11.4	49	2314	26.9	5.9	16	22	-
CCEH352 A 4	10.5	11.6	7.8	2	368	18.7	52	5213	25.5	5.1	16	22	-
CCEH352 B 4	12.2	13.9	9.3	2	368	17.3	52	4840	38.2	7.6	22	22	-
CCEH352 C 4	14.7	16.0	10.9	2	368	16.2	52	4515	50.9	10.1	22	28	-
CCEH353 A 4	15.9	17.3	11.7	3	552	23.0	54	7779	37.5	7.1	22	28	-
CCEH353 B 4	19.3	21.4	14.4	3	552	21.3	54	7209	56.2	10.7	22	28	-
CCEH353 C 4	20.7	23.2	15.7	3	552	19.8	54	6712	75.0	14.3	22	28	-
CCEH354 A 4	20.7	23.0	15.4	4	736	26.6	55	10350	49.5	9.2	22	28	-
CCEH354 B 4	24.2	27.5	18.4	4	736	24.6	55	9576	74.2	13.9	28	28	-
Fin spacing 4 mm, fan speed L													
COEL251 A 4	2.0	2.2	1.5	1	45	4.7	34	746	8.4	1.9	12	14	-
COEL251 B 4	2.4	2.7	1.8	1	45	4.5	34	718	12.6	2.8	12	16	-
COEL251 C 4	2.6	2.9	2.0	1	45	4.3	34	692	16.8	3.7	12	16	-
COEL252 A 4	4.0	4.4	3.0	2	90	6.7	37	1481	15.9	3.2	12	16	-
COEL252 B 4	4.7	5.2	3.5	2	90	6.4	37	1420	23.9	4.7	16	18	-
COEL252 C 4	5.2	5.6	3.9	2	90	6.2	37	1364	31.8	6.3	16	18	-
COEL253 A 4	5.8	6.4	4.3	3	135	8.3	39	2215	23.4	4.5	16	18	-
COEL253 B 4	7.1	7.8	5.3	3	135	7.9	39	2121	35.1	6.7	16	22	-
COEL253 C 4	7.7	8.4	5.8	3	135	7.6	39	2035	46.9	8.9	16	22	-
COEL254 A 4	7.9	8.6	5.9	4	180	9.6	40	2948	30.9	5.8	16	22	-
COEL254 B 4	9.3	10.3	7.0	4	180	9.2	40	2822	46.4	8.7	16	22	-
COEL351 A 4	4.1	4.5	3.1	1	65	8.3	42	1683	13.5	3.0	12	16	-
COEL351 B 4	4.9	5.3	3.7	1	65	7.6	42	1547	20.2	4.4	16	18	-
COEL351 C 4	5.3	5.7	3.9	1	65	7.1	42	1437	26.9	5.9	16	22	-
COEL352 A 4	8.0	8.8	5.9	2	130	11.9	45	3307	25.5	5.1	16	22	-
COEL352 B 4	9.2	10.2	6.9	2	130	10.8	45	3024	38.2	7.6	22	22	-
COEL352 C 4	10.2	11.1	7.6	2	130	10.0	45	2797	50.9	10.1	22	28	-
COEL353 A 4	11.9	12.9	8.8	3	195	14.6	47	4929	37.5	7.1	22	28	-
COEL353 B 4	14.1	15.4	10.5	3	195	13.3	47	4498	56.2	10.7	22	28	-
COEL353 C 4	14.8	16.3	11.1	3	195	12.3	47	4154	75.0	14.3	22	28	-
COEL354 A 4	15.7	17.3	11.7	4	260	16.8	48	6550	49.5	9.2	22	28	-
COEL354 B 4	18.2	20.2	13.7	4	260	15.4	48	5972	74.2	13.9	28	28	-

Model	Nominal capacities HFC DX			Draw-through AC fans 230/50/1							Connections		Stock model
	DT1 +2/-8 °C kW	SC2 kW	SC3 kW	fan power nr.	air throw W	sound pressure dB(A)	air flow m <sup>3</sup> /h	coil surface m <sup>2</sup>	Int. volume dm <sup>3</sup>	OD in mm	OD out mm		
CCE													
Fin spacing 5.5 mm, fan speed H													
CCEH251 A 5.5	2.4	1.8	1.4	1	118	7.9	54	1272	6.3	1.9	12	14	-
CCEH251 B 5.5	3.1	2.3	1.8	1	118	7.6	54	1226	9.5	2.8	12	16	-
CCEH251 C 5.5	3.6	2.7	2.1	1	118	7.4	54	1183	12.6	3.7	12	16	-
CCEH252 A 5.5	4.7	3.5	2.7	2	236	11.4	57	2525	11.9	3.2	12	16	-
CCEH252 B 5.5	6.0	4.5	3.5	2	236	11.0	57	2425	17.9	4.7	16	18	-
CCEH252 C 5.5	7.0	5.3	4.2	2	236	10.6	57	2333	23.9	6.3	16	18	-
CCEH253 A 5.5	6.8	5.1	3.9	3	354	14.1	59	3776	17.6	4.5	16	18	-
CCEH253 B 5.5	9.2	6.8	5.4	3	354	13.5	59	3624	26.4	6.7	16	22	-
CCEH253 C 5.5	10.3	7.7	6.1	3	354	13.0	59	3481	35.1	8.9	16	22	-
CCEH254 A 5.5	9.5	7.0	5.5	4	472	16.3	60	5027	23.2	5.8	16	22	-
CCEH254 B 5.5	11.8	8.9	6.9	4	472	15.7	60	4821	34.8	8.7	16	22	-
CCEH351 A 5.5	4.7	3.5	2.7	1	184	13.3	49	2700	10.1	3.0	12	16	-
CCEH351 B 5.5	6.0	4.5	3.5	1	184	12.6	49	2546	15.1	4.4	16	18	-
CCEH351 C 5.5	6.9	5.2	4.1	1	184	11.9	49	2408	20.2	5.9	16	22	-
CCEH352 A 5.5	9.1	6.8	5.3	2	368	19.1	52	5334	19.1	5.1	16	22	✓
CCEH352 B 5.5	11.1	8.4	6.4	2	368	17.9	52	5005	28.7	7.6	22	22	✓
CCEH352 C 5.5	13.5	10.0	8.0	2	368	16.9	52	4712	38.2	10.1	22	28	✓
CCEH353 A 5.5	13.7	10.1	7.9	3	552	23.5	54	7965	28.1	7.1	22	28	-
CCEH353 B 5.5	17.4	12.9	10.1	3	552	22.0	54	7460	42.2	10.7	22	28	✓
CCEH353 C 5.5	19.3	14.5	11.2	3	552	20.7	54	7011	56.2	14.3	22	28	✓
CCEH354 A 5.5	18.0	13.4	10.4	4	736	27.2	55	10600	37.1	9.2	22	28	-
CCEH354 B 5.5	22.1	16.6	12.7	4	736	25.5	55	9913	55.7	13.9	28	28	✓
Fin spacing 5.5 mm, fan speed L													
COEL251 A 5.5	1.7	1.3	1.0	1	45	4.7	34	758	6.3	1.9	12	14	-
COEL251 B 5.5	2.2	1.6	1.3	1	45	4.6	34	733	9.5	2.8	12	16	-
COEL251 C 5.5	2.4	1.8	1.5	1	45	4.4	34	711	12.6	3.7	12	16	-
COEL252 A 5.5	3.4	2.5	2.0	2	90	6.8	37	1505	11.9	3.2	12	16	-
COEL252 B 5.5	4.2	3.1	2.5	2	90	6.6	37	1452	17.9	4.7	16	18	-
COEL252 C 5.5	4.8	3.6	2.9	2	90	6.4	37	1405	23.9	6.3	16	18	-
COEL253 A 5.5	5.0	3.7	2.9	3	135	8.4	39	2252	17.6	4.5	16	18	-
COEL253 B 5.5	6.3	4.7	3.8	3	135	8.0	39	2171	26.4	6.7	16	22	-
COEL253 C 5.5	7.1	5.3	4.3	3	135	7.8	39	2098	35.1	8.9	16	22	-
COEL254 A 5.5	6.7	5.0	4.0	4	180	9.7	40	2999	23.2	5.8	16	22	-
COEL254 B 5.5	8.3	6.2	5.0	4	180	9.4	40	2889	34.8	8.7	16	22	-
COEL351 A 5.5	3.5	2.6	2.1	1	65	8.6	42	1735	10.1	3	12	16	-
COEL351 B 5.5	4.4	3.3	2.6	1	65	8.0	42	1614	15.1	4.4	16	18	-
COEL351 C 5.5	4.9	3.6	2.9	1	65	7.5	42	1512	20.2	5.9	16	22	-
COEL352 A 5.5	6.9	5.1	4.0	2	130	12.2	45	3417	19.1	5.1	16	22	-
COEL352 B 5.5	8.3	6.3	4.9	2	130	11.3	45	3161	28.7	7.6	22	22	-
COEL352 C 5.5	9.5	7.1	5.7	2	130	10.6	45	2950	38.2	10.1	22	28	-
COEL353 A 5.5	10.2	7.5	6.0	3	195	15.1	47	5097	28.1	7.1	22	28	-
COEL353 B 5.5	12.7	9.4	7.5	3	195	13.9	47	4706	42.2	10.7	22	28	-
COEL353 C 5.5	13.9	10.4	8.3	3	195	13.0	47	4385	56.2	14.3	22	28	-
COEL354 A 5.5	13.6	10.1	7.9	4	260	17.4	48	6776	37.1	9.2	22	28	-
COEL354 B 5.5	16.5	12.4	9.7	4	260	16.1	48	6251	55.7	13.9	28	28	-

Model	Nominal capacities HFC DX				Draw-through AC fans 230/50/1							Connections		Stock model
	DT1 +2/-8 °C	SC2	SC3	SC4	fan power nr.	air throw W	sound pressure dB(A)	air flow m <sup>3</sup> /h	coil surface m <sup>2</sup>	Int. volume dm <sup>3</sup>	OD in mm	OD out mm		
CCE	kW	kW	kW	kW										
Fin spacing 7 mm. fan speed H														
CCEH251 A 7	2.1	1.6	1.2	1.0	1	118	8.0	54	1288	5.1	1.9	12	14	-
CCEH251 B 7	2.8	2.1	1.6	1.3	1	118	7.8	54	1248	7.7	2.8	12	16	✓
CCEH251 C 7	3.3	2.5	2.0	1.6	1	118	7.5	54	1210	10.2	3.7	12	16	-✓
CCEH252 A 7	4.2	3.1	2.4	2.0	2	236	11.6	57	2559	9.7	3.2	12	16	✓
CCEH252 B 7	5.4	4.0	3.2	2.5	2	236	11.2	57	2472	14.5	4.7	16	18	✓
CCEH252 C 7	6.5	4.8	3.8	3.1	2	236	10.8	57	2391	19.4	6.3	16	18	✓
CCEH253 A 7	6.1	4.5	3.5	2.8	3	354	14.3	59	3829	14.2	4.5	16	18	-
CCEH253 B 7	8.2	6.1	4.9	4.0	3	354	13.8	59	3695	21.4	6.7	16	22	-
CCEH253 C 7	9.5	7.1	5.6	4.6	3	354	13.3	59	3571	28.5	8.9	16	22	-
CCEH254 A 7	8.3	6.1	4.9	4.0	4	472	16.6	60	5098	18.8	5.8	16	22	-
CCEH254 B 7	10.7	8.0	6.3	5.1	4	472	16.0	60	4918	28.2	8.7	16	22	-
CCEH351 A 7	4.1	3.1	2.4	1.9	1	184	13.6	49	2752	8.2	3.0	12	16	-
CCEH351 B 7	5.4	4.0	3.2	2.6	1	184	12.9	49	2618	12.3	4.4	16	18	-
CCEH351 C 7	6.4	4.7	3.8	3.1	1	184	12.3	49	2495	16.4	5.9	16	22	✓
CCEH352 A 7	8.1	6.0	4.7	3.8	2	368	19.5	52	5447	15.5	5.1	16	22	✓
CCEH352 B 7	10.2	7.7	5.9	4.7	2	368	18.5	52	5158	23.2	7.6	22	22	✓
CCEH352 C 7	12.4	9.2	7.3	6.0	2	368	17.5	52	4895	31.0	10.1	22	28	✓
CCEH353 A 7	12.0	8.8	7.0	5.7	3	552	24.0	54	8140	22.8	7.1	22	28	-
CCEH353 B 7	15.7	11.7	9.2	7.5	3	552	22.7	54	7695	34.2	10.7	22	28	✓
CCEH353 C 7	18.0	13.5	10.5	8.4	3	552	21.5	54	7292	45.6	14.3	22	28	✓
CCEH354 A 7	15.9	11.8	9.2	7.5	4	736	27.8	55	10830	30.1	9.2	22	28	-
CCEH354 B 7	20.2	15.2	11.7	9.3	4	736	26.3	55	10230	45.1	13.9	28	28	✓
Fin spacing 7 mm. fan speed L														
COEL251 A 7	1.5	1.1	0.9	0.7	1	45	4.8	34	767	5.1	1.9	12	14	-
COEL251 B 7	1.9	1.5	1.2	1.0	1	45	4.6	34	745	7.7	2.8	12	16	-
COEL251 C 7	2.3	1.7	1.4	1.1	1	45	4.5	34	725	10.2	3.7	12	16	✓
COEL252 A 7	3.0	2.2	1.8	1.4	2	90	6.9	37	1524	9.7	3.2	12	16	✓
COEL252 B 7	3.8	2.8	2.3	1.9	2	90	6.7	37	1477	14.5	4.7	16	18	✓
COEL252 C 7	4.4	3.3	2.7	2.2	2	90	6.5	37	1435	19.4	6.3	16	18	✓
COEL253 A 7	4.4	3.3	2.6	2.1	3	135	8.5	39	2281	14.2	4.5	16	18	-
COEL253 B 7	5.7	4.2	3.4	2.8	3	135	8.2	39	2208	21.4	6.7	16	22	✓
COEL253 C 7	6.6	4.9	3.9	3.2	3	135	8.0	39	2144	28.5	8.9	16	22	✓
COEL254 A 7	5.9	4.3	3.5	2.9	4	180	9.9	40	3037	18.8	5.8	16	22	-
COEL254 B 7	7.5	5.6	4.5	3.7	4	180	9.6	40	2940	28.2	8.7	16	22	✓
COEL351 A 7	3.1	2.3	1.8	1.5	1	65	8.8	42	1778	8.2	3.0	12	16	-
COEL351 B 7	4.0	3.0	2.4	1.9	1	65	8.2	42	1669	12.3	4.4	16	18	-
COEL351 C 7	4.6	3.4	2.7	2.2	1	65	7.8	42	1575	16.4	5.9	16	22	-
COEL352 A 7	6.1	4.5	3.6	2.9	2	130	12.6	45	3509	15.5	5.1	16	22	-
COEL352 B 7	7.6	5.7	4.5	3.6	2	130	11.7	45	3277	23.2	7.6	22	22	-
COEL352 C 7	8.9	6.6	5.3	4.4	2	130	11.0	45	3080	31.0	10.1	22	28	-
COEL353 A 7	9.0	6.6	5.2	4.3	3	195	15.5	47	5238	22.8	7.1	22	28	-
COEL353 B 7	11.5	8.6	6.8	5.6	3	195	14.4	47	4883	34.2	10.7	22	28	-
COEL353 C 7	13.0	9.7	7.7	6.3	3	195	13.5	47	4583	45.6	14.3	22	28	-
COEL354 A 7	12.0	8.9	7.0	5.7	4	260	17.9	48	6966	30.1	9.2	22	28	-
COEL354 B 7	15.1	11.3	8.9	7.2	4	260	16.7	48	6489	45.1	13.9	28	28	-

Model	Nominal capacities HFC DX			Draw-through AC fans 400/50/3							Connections		Stock model
	DT1 +2/-8 °C kW	SC1 kW	SC2 kW	fan power nr. W	air throw m	sound pressure dB(A)	air flow m <sup>3</sup> /h	coil surface m <sup>2</sup>	Int. volume dm <sup>3</sup>	OD in mm	OD out mm		
CCE													
Fin spacing 4 mm, fan speed H													
CCEH251 A 4	<b>2.8</b>	3.2	2.1	1	100	8.1	58	1304	8.4	1.9	12	14	-
CCEH251 B 4	<b>3.6</b>	4.0	2.7	1	100	7.8	58	1255	12.6	2.8	12	16	-
CCEH251 C 4	<b>4.1</b>	4.5	3.1	1	100	7.5	58	1209	16.8	3.7	12	16	-
CCEH252 A 4	<b>5.6</b>	6.2	4.2	2	200	11.7	61	2588	15.9	3.2	12	16	-
CCEH252 B 4	<b>6.8</b>	7.7	5.2	2	200	11.3	61	2482	23.9	4.7	16	18	-
CCEH252 C 4	<b>8.0</b>	8.8	6.0	2	200	10.8	61	2384	31.8	6.3	16	18	-
CCEH253 A 4	<b>7.9</b>	9.0	6.0	3	300	14.5	63	3871	23.4	4.5	16	18	-
CCEH253 B 4	<b>10.6</b>	11.7	7.9	3	300	13.9	63	3709	35.1	6.7	16	22	-
CCEH253 C 4	<b>11.6</b>	12.9	8.8	3	300	13.3	63	3556	46.9	8.9	16	22	-
CCEH254 A 4	<b>11.3</b>	12.5	8.4	4	400	16.8	64	5154	30.9	5.8	16	22	-
CCEH254 B 4	<b>13.5</b>	15.2	10.2	4	400	16.0	64	4934	46.4	8.7	16	22	-
CCEH351 A 4	<b>5.2</b>	5.8	3.9	1	170	12.3	48	2493	13.5	3.0	12	16	-
CCEH351 B 4	<b>6.5</b>	7.2	4.9	1	170	11.5	48	2334	20.2	4.4	16	18	-
CCEH351 C 4	<b>7.2</b>	7.9	5.4	1	170	10.8	48	2188	26.9	5.9	16	22	-
CCEH352 A 4	<b>10.2</b>	11.2	7.6	2	340	17.6	51	4919	25.5	5.1	16	22	-
CCEH352 B 4	<b>11.9</b>	13.4	9.0	2	340	16.4	51	4578	38.2	7.6	22	22	-
CCEH352 C 4	<b>14.1</b>	15.4	10.5	2	340	15.3	51	4267	50.9	10.1	22	28	-
CCEH353 A 4	<b>15.3</b>	16.7	11.3	3	510	21.7	53	7343	37.5	7.1	22	28	-
CCEH353 B 4	<b>18.6</b>	20.6	13.9	3	510	20.1	53	6818	56.2	10.7	22	28	-
CCEH353 C 4	<b>20.0</b>	22.3	15.1	3	510	18.7	53	6342	75.0	14.3	22	28	-
CCEH354 A 4	<b>20.0</b>	22.2	14.9	4	680	25.1	54	9766	49.5	9.2	22	28	-
CCEH354 B 4	<b>23.5</b>	26.6	17.8	4	680	23.3	54	9058	74.2	13.9	28	28	-

Model	Nominal capacities HFC DX			Draw-through AC fans 400/50/3						Connections		Stock model	
	DT1 +2/-8 °C kW	SC1 kW	SC2 kW	fan power nr.	air throw W	sound pressure dB(A)	air flow m <sup>3</sup> /h	coil surface m <sup>2</sup>	Int. volume dm <sup>3</sup>	OD in mm	OD out mm		
CCE													
Fin spacing 4 mm, fan speed H													
CCEH401 A 4	7.3	8.0	5.4	1	280	16.0	53	3653	17.0	3.7	16	18	-
CCEH401 B 4	8.6	9.7	6.5	1	280	14.8	53	3367	25.5	5.5	16	18	-
CCEH401 C 4	9.9	10.9	7.4	1	280	13.7	53	3122	34.1	7.3	16	22	-
CCEH402 A 4	13.8	15.6	10.4	2	560	22.8	56	7254	33.3	6.5	16	22	-
CCEH402 B 4	15.5	18.1	11.9	2	560	20.9	56	6668	49.9	9.8	16	22	-
CCEH402 C 4	19.5	21.5	14.6	2	560	19.3	56	6169	66.5	13.0	22	35	-
CCEH403 A 4	21.5	23.7	15.9	3	840	27.9	58	10850	49.5	9.3	22	28	-
CCEH403 B 4	25.5	28.7	19.2	3	840	25.6	58	9968	74.2	14.0	22	28	-
CCEH403 C 4	26.8	30.6	20.5	3	840	23.7	58	9214	98.9	18.7	22	28	-
CCEH404 A 4	27.5	31.0	20.7	4	1120	32.3	59	14450	65.7	12.1	22	28	-
CCEH404 B 4	31.0	36.0	23.8	4	1120	29.6	59	13270	98.5	18.2	22	28	-
CCEH404 C 4	35.7	40.8	27.2	4	1120	27.4	59	12260	131.4	24.3	22	35	-
CCEH501 A 4	13.8	15.6	10.3	1	720	22.4	55	6844	49.9	11.1	16	35	-
CCEH501 B 4	17.6	19.5	13.1	1	720	20.7	55	6333	74.8	16.7	22	35	-
CCEH501 C 4	18.9	21.1	14.2	1	720	19.3	55	5915	99.8	22.3	22	42	-
CCEH502 A 4	26.0	30.0	19.8	2	1440	31.6	58	13690	99.8	20.4	22	42	-
CCEH502 B 4	34.8	38.8	26.0	2	1440	29.3	58	12670	149.7	30.5	28	42	-
CCEH502 C 4	37.9	42.4	28.5	2	1440	27.3	58	11830	199.5	40.8	28	42	-
CCEH503 A 4	42.4	47.4	31.5	3	2160	38.7	60	20530	149.7	29.6	28	42	-
CCEH503 B 4	45.7	53.5	35.2	3	2160	35.8	60	19000	224.5	44.4	28	42	-
CCEH503 C 4	56.9	63.6	42.8	3	2160	33.5	60	17750	299.3	59.2	28	42	-
CCEH504 A 4	57.4	63.5	42.4	4	2880	44.7	61	27370	199.5	38.8	28	54	-
CCEH504 B 4	66.8	75.8	50.5	4	2880	41.4	61	25330	299.3	58.3	28	54	-
CCEH504 C 4	75.9	84.9	57.1	4	2880	38.7	61	23660	399.1	77.7	28	54	-
Fin spacing 4 mm, fan speed L													
CCEL401 A 4	5.4	5.9	4.0	1	120	9.7	43	2220	17.0	3.7	16	18	-
CCEL401 B 4	6.3	6.9	4.7	1	120	8.9	43	2038	25.5	5.5	16	18	-
CCEL401 C 4	6.8	7.4	5.1	1	120	8.3	43	1886	34.1	7.3	16	22	-
CCEL402 A 4	10.4	11.5	7.8	2	240	13.8	46	4406	33.3	6.5	16	22	-
CCEL402 B 4	11.8	13.3	8.9	2	240	12.7	46	4034	49.9	9.8	16	22	-
CCEL402 C 4	13.5	14.7	10.1	2	240	11.7	46	3725	66.5	13.0	22	35	-
CCEL403 A 4	15.9	17.3	11.7	3	360	17.0	48	6592	49.5	9.3	22	28	-
CCEL403 B 4	18.6	20.4	13.9	3	360	15.5	48	6030	74.2	14.0	22	28	-
CCEL403 C 4	19.3	21.5	14.6	3	360	14.3	48	5564	98.9	18.7	22	28	-
CCEL404 A 4	20.8	23.0	15.5	4	480	19.6	49	8777	65.7	12.1	22	28	-
CCEL404 B 4	23.5	26.5	17.8	4	480	17.9	49	8025	98.5	18.2	22	28	-
CCEL404 C 4	25.7	28.6	19.4	4	480	16.5	49	7403	131.4	24.3	22	35	-
CCEL501 A 4	10.9	12.1	8.1	1	290	14.8	45	4535	49.9	11.1	16	35	-
CCEL501 B 4	13.3	14.5	9.8	1	290	13.7	45	4187	74.8	16.7	22	35	-
CCEL501 C 4	14.0	15.5	10.5	1	290	12.7	45	3875	99.8	22.3	22	42	-
CCEL502 A 4	21.1	23.8	15.9	2	580	21.0	48	9071	99.8	20.4	22	42	-
CCEL502 B 4	26.4	29.0	19.6	2	580	19.3	48	8375	149.7	30.5	28	42	-
CCEL502 C 4	28.2	31.0	21.1	2	580	17.9	48	7751	199.5	40.8	28	42	-
CCEL503 A 4	33.2	36.5	24.5	3	870	25.7	50	13610	149.7	29.6	28	42	-
CCEL503 B 4	36.7	41.7	27.9	3	870	23.7	50	12560	224.5	44.4	28	42	-
CCEL503 C 4	42.3	46.5	31.6	3	870	21.9	50	11630	299.3	59.2	28	42	-
CCEL504 A 4	44.5	48.6	32.7	4	1160	29.6	51	18140	199.5	38.8	28	54	-
CCEL504 B 4	51.8	57.5	38.8	4	1160	27.4	51	16750	299.3	58.3	28	54	-
CCEL504 C 4	56.4	62.0	42.1	4	1160	25.3	51	15500	399.1	77.7	28	54	-



Model	Nominal capacities HFC DX				Draw-through AC fans 400/50/3							Connections		Stock model
	DT1 +2/-8 °C	SC2	SC3	SC4	fan power nr.	air throw W	sound pressure dB(A)	air flow m <sup>3</sup> /h	coil surface m <sup>2</sup>	Int. volume dm <sup>3</sup>	in mm	out mm		
CCE														
Fin spacing 7 mm, fan speed H														
CCEH251 A 7	2.2	1.6	1.3	1.0	1	100	8.3	58	1337	5.1	1.9	12	14	-
CCEH251 B 7	2.9	2.1	1.7	1.4	1	100	8.1	58	1298	7.7	2.8	12	16	-
CCEH251 C 7	3.4	2.5	2.0	1.6	1	100	7.9	58	1264	10.2	3.7	12	16	-
CCEH252 A 7	4.3	3.2	2.5	2.0	2	200	12.0	61	2658	9.7	3.2	12	16	-
CCEH252 B 7	5.5	4.2	3.2	2.6	2	200	11.7	61	2575	14.5	4.7	16	18	-
CCEH252 C 7	6.7	5.0	4.0	3.2	2	200	11.3	61	2501	19.4	6.3	16	18	-
CCEH253 A 7	6.2	4.6	3.6	2.9	3	300	14.9	63	3977	14.2	4.5	16	18	-
CCEH253 B 7	8.5	6.3	5.0	4.1	3	300	14.4	63	3851	21.4	6.7	16	22	-
CCEH253 C 7	9.8	7.4	5.8	4.7	3	300	14.0	63	3737	28.5	8.9	16	22	-
CCEH254 A 7	8.5	6.3	5.0	4.1	4	400	17.2	64	5297	18.8	5.8	16	22	-
CCEH254 B 7	11.0	8.2	6.4	5.2	4	400	16.7	64	5126	28.2	8.7	16	22	-
CCEH351 A 7	4.0	3.0	2.3	1.9	1	170	12.8	48	2595	8.2	3.0	12	16	-
CCEH351 B 7	5.2	3.9	3.1	2.5	1	170	12.2	48	2471	12.3	4.4	16	18	-
CCEH351 C 7	6.1	4.6	3.6	3.0	1	170	11.6	48	2359	16.4	5.9	16	22	-
CCEH352 A 7	7.8	5.8	4.5	3.7	2	340	18.4	51	5136	15.5	5.1	16	22	-
CCEH352 B 7	9.8	7.4	5.7	4.6	2	340	17.5	51	4872	23.2	7.6	22	22	-
CCEH352 C 7	12.0	8.9	7.1	5.8	2	340	16.6	51	4631	31.0	10.1	22	28	-
CCEH353 A 7	11.6	8.5	6.7	5.5	3	510	22.7	53	7675	22.8	7.1	22	28	-
CCEH353 B 7	15.1	11.2	8.9	7.2	3	510	21.5	53	7269	34.2	10.7	22	28	-
CCEH353 C 7	17.3	13.0	10.1	8.2	3	510	20.4	53	6900	45.6	14.3	22	28	-
CCEH354 A 7	15.3	11.4	8.9	7.2	4	680	26.3	54	10210	30.1	9.2	22	28	-
CCEH354 B 7	19.5	14.6	11.3	9.1	4	680	24.8	54	9666	45.1	13.9	28	28	-

Model	Nominal capacities HFC DX				Draw-through AC fans 400/50/3							Connections		Stock model
	DT1 +2/-8 °C	SC2	SC3	SC4	fan power nr.	air throw W	sound pressure dB(A)	air flow m <sup>3</sup> /h	coil surface m <sup>2</sup>	Int. volume dm <sup>3</sup>	OD			
											in mm	out mm		
CCE	kW	kW	kW	kW										
Fin spacing 7 mm, fan speed H														
CCEH401 A 7	5.6	4.1	3.2	2.6	1	280	16.8	53	3836	10.4	3.7	16	18	-
CCEH401 B 7	7.1	5.3	4.1	3.3	1	280	15.8	53	3609	15.5	5.5	16	18	-
CCEH401 C 7	8.5	6.3	5.0	4.0	1	280	14.9	53	3408	20.7	7.3	16	22	-
CCEH402 A 7	10.8	8.1	6.3	5.0	2	560	23.9	56	7630	20.2	6.5	16	22	-
CCEH402 B 7	13.3	10.1	7.6	5.9	2	560	22.5	56	7164	30.3	9.8	16	22	-
CCEH402 C 7	16.8	12.5	9.9	8.0	2	560	21.2	56	6749	40.4	13.0	22	35	-
CCEH403 A 7	16.5	12.2	9.5	7.8	3	840	29.4	58	11420	30.1	9.3	22	28	-
CCEH403 B 7	21.1	15.8	12.3	9.9	3	840	27.6	58	10720	45.1	14.0	22	28	✓
CCEH403 C 7	23.7	17.9	13.7	10.8	3	840	25.9	58	10090	60.2	18.7	22	28	-
CCEH404 A 7	21.6	16.1	12.5	10.0	4	1120	34.0	59	15220	39.9	12.1	22	28	-
CCEH404 B 7	26.5	20.1	15.1	11.9	4	1120	31.8	59	14270	59.9	18.2	22	28	-
CCEH404 C 7	31.5	23.8	18.2	14.5	4	1120	30.0	59	13430	79.9	24.3	22	35	-
CCEH501 A 7	10.5	7.8	5.9	4.8	1	720	23.9	55	7329	29.7	11.1	16	35	-
CCEH501 B 7	14.0	10.3	8.0	6.5	1	720	22.7	55	6949	44.5	16.7	22	35	-
CCEH501 C 7	16.2	12.1	9.4	7.5	1	720	21.6	55	6616	59.4	22.3	22	42	-
CCEH502 A 7	20.4	15.3	11.5	9.2	2	1440	33.9	58	14660	59.4	20.4	22	42	-
CCEH502 B 7	27.9	20.7	16.0	12.9	2	1440	32.1	58	13900	89.0	30.5	28	42	-
CCEH502 C 7	32.5	24.3	18.8	15.1	2	1440	30.6	58	13230	118.7	40.8	28	42	✓
CCEH503 A 7	31.8	23.4	18.0	14.5	3	2160	41.5	60	21990	89.0	29.6	28	42	-
CCEH503 B 7	38.7	29.4	22.0	17.4	3	2160	39.3	60	20850	133.5	44.4	28	42	✓
CCEH503 C 7	48.9	36.4	28.2	22.7	3	2160	37.4	60	19850	178.1	59.2	28	42	✓
CCEH504 A 7	42.5	31.1	24.0	19.4	4	2880	47.9	61	29320	118.7	38.8	28	54	-
CCEH504 B 7	54.7	40.9	31.3	25.1	4	2880	45.4	61	27800	178.1	58.3	28	54	✓
CCEH504 C 7	65.2	48.6	37.6	30.3	4	2880	43.2	61	26470	237.4	77.7	28	54	✓
Fin spacing 7 mm, fan speed L														
COEL401 A 7	4.1	3.0	2.4	1.9	1	120	10.3	43	2344	10.4	3.7	16	18	-
COEL401 B 7	5.2	3.8	3.0	2.5	1	120	9.6	43	2201	15.5	5.5	16	18	-
COEL401 C 7	5.9	4.4	3.5	2.9	1	120	9.1	43	2074	20.7	7.3	16	22	-
COEL402 A 7	8.0	5.9	4.7	3.8	2	240	14.6	46	4661	20.2	6.5	16	22	-
COEL402 B 7	9.9	7.4	5.8	4.6	2	240	13.7	46	4367	30.3	9.8	16	22	-
COEL402 C 7	11.7	8.7	7.0	5.8	2	240	12.9	46	4108	40.4	13.0	22	35	-
COEL403 A 7	12.0	8.8	7.0	5.8	3	360	17.9	48	6979	30.1	9.3	22	28	-
COEL403 B 7	15.3	11.4	9.0	7.4	3	360	16.8	48	6533	45.1	14.0	22	28	-
COEL403 C 7	17.1	12.9	10.1	8.2	3	360	15.8	48	6141	60.2	18.7	22	28	-
COEL404 A 7	15.9	11.8	9.3	7.6	4	480	20.7	49	9296	39.9	12.1	22	28	-
COEL404 B 7	19.7	14.8	11.5	9.3	4	480	19.4	49	8698	59.9	18.2	22	28	-
COEL404 C 7	22.8	17.1	13.5	10.9	4	480	18.2	49	8173	79.9	24.3	22	35	-
COEL501 A 7	8.3	6.1	4.7	3.8	1	290	15.8	45	4841	29.7	11.1	16	35	-
COEL501 B 7	10.8	7.9	6.2	5.1	1	290	15.1	45	4609	44.5	16.7	22	35	-
COEL501 C 7	12.4	9.2	7.3	5.9	1	290	14.4	45	4394	59.4	22.3	22	42	-
COEL502 A 7	16.3	12.1	9.3	7.5	2	580	22.4	48	9681	59.4	20.4	22	42	-
COEL502 B 7	21.6	15.9	12.5	10.2	2	580	21.3	48	9217	89.0	30.5	28	42	-
COEL502 C 7	24.9	18.5	14.6	11.9	2	580	20.3	48	8787	118.7	40.8	28	42	-
COEL503 A 7	24.9	18.3	14.2	11.6	3	870	27.4	50	14520	89.0	29.6	28	42	-
COEL503 B 7	31.0	23.3	17.9	14.4	3	870	26.1	50	13830	133.5	44.4	28	42	-
COEL503 C 7	37.4	27.7	21.9	17.8	3	870	24.9	50	13180	178.1	59.2	28	42	-
COEL504 A 7	33.1	24.2	18.9	15.3	4	1160	31.6	51	19360	118.7	38.8	28	54	-
COEL504 B 7	42.8	31.8	24.8	20.1	4	1160	30.1	51	18430	178.1	58.3	28	54	-
COEL504 C 7	49.8	37.0	29.2	23.7	4	1160	28.7	51	17570	237.4	77.7	28	54	-

Model	Nominal capacities HFC DX				Draw-through AC fans 400/50/3							Connections		Stock model	
	DT1 +2/-8 °C	SC2	SC3	SC4	nr.	fan	air	sound	air	coil	Int.	OD			
						power	throw	pressure	flow	surface	volume	in	out		
<b>CCE</b>	<b>kW</b>	<b>kW</b>	<b>kW</b>	<b>kW</b>		<b>W</b>	<b>m</b>	<b>dB(A)</b>	<b>m<sup>3</sup>/h</b>	<b>m<sup>2</sup></b>	<b>dm<sup>3</sup></b>	<b>mm</b>	<b>mm</b>		
Fin spacing 10 mm, fan speed H															
CCEH501 A 10	8.7	6.4	4.9	4.0	1	720	24.5	55	7490	21.6	11.1	16	35	-	
CCEH501 B 10	11.9	8.7	6.8	5.5	1	720	23.4	55	7163	32.4	16.7	22	35	-	
CCEH501 C 10	14.2	10.6	8.2	6.6	1	720	22.4	55	6870	43.2	22.3	22	42	-	
CCEH502 A 10	17.2	12.8	9.8	7.8	2	1440	34.6	58	14980	43.2	20.4	22	42	-	
CCEH502 B 10	23.8	17.5	13.6	11.0	2	1440	33.1	58	14330	64.8	30.5	28	42	-	
CCEH502 C 10	28.5	21.2	16.5	13.3	2	1440	31.7	58	13740	86.4	40.8	28	42	-	
CCEH503 A 10	26.3	19.3	14.9	12.1	3	2160	42.4	60	22470	64.8	29.6	28	42	-	
CCEH503 B 10	33.9	25.5	19.3	15.4	3	2160	40.5	60	21490	97.2	44.4	28	42	-	
CCEH503 C 10	42.8	31.8	24.7	20.0	3	2160	38.9	60	20610	129.6	59.2	28	42	-	
CCEH504 A 10	35.0	25.5	19.8	16.0	4	2880	48.9	61	29960	86.4	38.8	28	54	-	
CCEH504 B 10	47.0	34.9	26.9	21.7	4	2880	46.8	61	28650	129.6	58.3	28	54	-	
CCEH504 C 10	57.1	42.3	33.0	26.7	4	2880	44.9	61	27480	172.8	77.7	28	54	-	
Fin spacing 10 mm, fan speed L															
CCEL501 A 10	6.9	5.0	3.9	3.2	1	290	16.2	45	4944	21.6	11.1	16	35	-	
CCEL501 B 10	9.2	6.7	5.3	4.3	1	290	15.5	45	4744	32.4	16.7	22	35	-	
CCEL501 C 10	11.0	8.1	6.4	5.2	1	290	14.9	45	4565	43.2	22.3	22	42	-	
CCEL502 A 10	13.7	10.1	7.8	6.3	2	580	22.8	48	9889	43.2	20.4	22	42	-	
CCEL502 B 10	18.4	13.5	10.6	8.7	2	580	21.9	48	9489	64.8	30.5	28	42	-	
CCEL502 C 10	22.0	16.2	12.8	10.5	2	580	21.1	48	9131	86.4	40.8	28	42	-	
CCEL503 A 10	20.6	15.1	11.8	9.6	3	870	28.0	50	14830	64.8	29.6	28	42	-	
CCEL503 B 10	27.0	20.1	15.6	12.6	3	870	26.8	50	14230	97.2	44.4	28	42	-	
CCEL503 C 10	32.9	24.4	19.2	15.7	3	870	25.8	50	13700	129.6	59.2	28	42	-	
CCEL504 A 10	27.3	19.9	15.6	12.7	4	1160	32.3	51	19780	86.4	38.8	28	54	-	
CCEL504 B 10	36.7	27.2	21.3	17.3	4	1160	31.0	51	18980	129.6	58.3	28	54	-	
CCEL504 C 10	43.9	32.5	25.6	20.9	4	1160	29.8	51	18260	172.8	77.7	28	54	-	
Fin spacing 12 mm, fan speed H															
CCEH501 A 12	8.0	5.9	4.5	3.7	1	720	24.6	55	7537	18.5	11.1	16	35	-	
CCEH501 B 12	11.0	8.0	6.3	5.1	1	720	23.6	55	7227	27.7	16.7	22	35	-	
CCEH501 C 12	13.3	9.8	7.7	6.2	1	720	22.7	55	6948	36.9	22.3	22	42	-	
CCEH502 A 12	15.8	11.7	9.0	7.2	2	1440	34.8	58	15070	36.9	20.4	22	42	-	
CCEH502 B 12	22.0	16.1	12.6	10.2	2	1440	33.4	58	14450	55.4	30.5	28	42	-	
CCEH502 C 12	26.6	19.7	15.4	12.5	2	1440	32.1	58	13900	73.8	40.8	28	42	-	
CCEH503 A 12	24.0	17.6	13.6	11.1	3	2160	42.7	60	22610	55.4	29.6	28	42	-	
CCEH503 B 12	31.6	23.7	18.1	14.5	3	2160	40.9	60	21680	83.0	44.4	28	42	-	
CCEH503 C 12	40.0	29.6	23.1	18.7	3	2160	39.3	60	20840	110.7	59.2	28	42	-	
CCEH504 A 12	32.0	23.3	18.1	14.7	4	2880	49.2	61	30150	73.8	38.8	28	54	-	
CCEH504 B 12	43.6	32.3	25.0	20.2	4	2880	47.2	61	28910	110.7	58.3	28	54	-	
CCEH504 C 12	53.3	39.5	30.8	24.9	4	2880	45.4	61	27790	147.6	77.7	28	54	-	
Fin spacing 12 mm, fan speed L															
CCEL501 A 12	6.3	4.6	3.6	2.9	1	290	16.3	45	4977	18.5	11.1	16	35	-	
CCEL501 B 12	8.5	6.2	4.9	4.0	1	290	15.6	45	4787	27.7	16.7	22	35	-	
CCEL501 C 12	10.3	7.6	6.0	4.9	1	290	15.1	45	4618	36.9	22.3	22	42	-	
CCEL502 A 12	12.6	9.3	7.2	5.9	2	580	23.0	48	9954	36.9	20.4	22	42	-	
CCEL502 B 12	17.0	12.5	9.8	8.0	2	580	22.1	48	9573	55.4	30.5	28	42	-	
CCEL502 C 12	20.6	15.2	12.0	9.8	2	580	21.3	48	9236	73.8	40.8	28	42	-	
CCEL503 A 12	18.8	13.8	10.8	8.8	3	870	28.2	50	14930	55.4	29.6	28	42	-	
CCEL503 B 12	25.1	18.7	14.6	11.8	3	870	27.1	50	14360	83.0	44.4	28	42	-	
CCEL503 C 12	30.8	22.8	18.0	14.7	3	870	26.1	50	13850	110.7	59.2	28	42	-	
CCEL504 A 12	25.0	18.2	14.2	11.6	4	1160	32.5	51	19910	73.8	38.8	28	54	-	
CCEL504 B 12	34.1	25.2	19.7	16.1	4	1160	31.3	51	19150	110.7	58.3	28	54	-	
CCEL504 C 12	41.1	30.4	24.0	19.6	4	1160	30.2	51	18470	147.6	77.7	28	54	-	

Model  CCX	Nominal capacities CO <sub>2</sub> DX		Draw-through AC fans 230/50/1							Connections		Stock model
	DT1 +2/-8 °C kW	SC2 kW	fan power nr.	air throw W	sound pressure dB(A)	air flow m <sup>3</sup> /h	coil surface m <sup>2</sup>	Int. volume dm <sup>3</sup>	OD			
									in mm	out mm		
Fin spacing 4 mm. fan speed H												
CCXH251 A 4	2.6	1.9	1	118	8.0	54	1275	8.6	1.1	8	10	-
CCXH251 B 4	3.4	2.5	1	118	7.7	54	1230	12.9	1.6	12	12	-
CCXH251 C 4	3.8	2.8	1	118	7.4	54	1187	17.1	2.2	12	12	-
CCXH252 A 4	5.0	3.8	2	236	11.5	57	2531	16.2	1.9	12	12	-
CCXH252 B 4	6.5	4.8	2	236	11.0	57	2434	24.3	2.8	12	12	-
CCXH252 C 4	7.4	5.5	2	236	10.6	57	2343	32.5	3.7	12	12	-
CCXH253 A 4	7.6	5.7	3	354	14.2	59	3787	23.9	2.6	12	12	-
CCXH253 B 4	9.7	7.2	3	354	13.6	59	3637	35.8	3.9	12	12	-
CCXH253 C 4	11.2	8.3	3	354	13.1	59	3496	47.8	5.2	16	12	-
CCXH254 A 4	10.0	7.4	4	472	16.4	60	5042	31.5	3.4	12	12	-
CCXH254 B 4	12.6	9.4	4	472	15.7	60	4840	47.3	5.1	12	12	-
CCXH351 A 4	4.9	3.7	1	184	13.4	49	2715	13.7	1.7	12	12	-
CCXH351 B 4	6.4	4.7	1	184	12.7	49	2566	20.6	2.6	12	12	-
CCXH351 C 4	7.3	5.4	1	184	12.0	49	2430	27.4	3.5	12	12	-
CCXH352 A 4	9.6	7.2	2	368	19.2	52	5370	26.0	3.0	12	12	-
CCXH352 B 4	12.4	9.2	2	368	18.1	52	5049	38.9	4.4	16	12	-
CCXH352 C 4	14.2	10.6	2	368	17.1	52	4760	51.9	5.9	16	12	-
CCXH353 A 4	14.5	10.7	3	552	23.7	54	8022	38.2	4.2	16	14	-
CCXH353 B 4	18.3	13.6	3	552	22.2	54	7529	57.3	6.3	16	14	-
CCXH353 C 4	21.2	15.7	3	552	20.9	54	7086	76.4	8.4	22	14	-
CCXH354 A 4	19.0	14.1	4	736	27.4	55	10670	50.5	5.4	16	14	-
CCXH354 B 4	24.6	18.2	4	736	25.7	55	10010	75.7	8.1	22	14	-
Fin spacing 4 mm. fan speed L												
CCXL251 A 4	1.9	1.4	1	45	4.7	34	758	8.6	1.1	8	10	-
CCXL251 B 4	2.3	1.7	1	45	4.6	34	733	12.9	1.6	12	12	-
CCXL251 C 4	2.6	1.9	1	45	4.4	34	710	17.1	2.2	12	12	-
CCXL252 A 4	3.7	2.7	2	90	6.8	37	1505	16.2	1.9	12	12	-
CCXL252 B 4	4.6	3.4	2	90	6.6	37	1452	24.3	2.8	12	12	-
CCXL252 C 4	5.1	3.8	2	90	6.4	37	1403	32.5	3.7	12	12	-
CCXL253 A 4	5.5	4.1	3	135	8.4	39	2252	23.9	2.6	12	12	-
CCXL253 B 4	6.8	5.1	3	135	8.1	39	2170	35.8	3.9	12	12	-
CCXL253 C 4	7.6	5.7	3	135	7.8	39	2096	47.8	5.2	16	12	-
CCXL254 A 4	7.3	5.4	4	180	9.7	40	2998	31.5	3.4	12	12	-
CCXL254 B 4	9.0	6.7	4	180	9.4	40	2888	47.3	5.1	12	12	-
CCXL351 A 4	3.8	2.8	1	65	8.6	42	1740	13.7	1.7	12	12	-
CCXL351 B 4	4.7	3.5	1	65	8.0	42	1618	20.6	2.6	12	12	-
CCXL351 C 4	5.2	3.9	1	65	7.5	42	1515	27.4	3.5	12	12	-
CCXL352 A 4	7.4	5.5	2	130	12.3	45	3429	26.0	3	12	12	-
CCXL352 B 4	9.2	6.8	2	130	11.4	45	3172	38.9	4.4	16	12	-
CCXL352 C 4	10.1	7.5	2	130	10.6	45	2958	51.9	5.9	16	12	-
CCXL353 A 4	11.1	8.2	3	195	15.1	47	5116	38.2	4.2	16	14	-
CCXL353 B 4	13.5	10.1	3	195	14.0	47	4724	57.3	6.3	16	14	-
CCXL353 C 4	15.0	11.2	3	195	13.0	47	4399	76.4	8.4	22	14	-
CCXL354 A 4	14.7	10.9	4	260	17.5	48	6802	50.5	5.4	16	14	-
CCXL354 B 4	18.1	13.4	4	260	16.1	48	6275	75.7	8.1	22	14	-

Model	Nominal capacities CO <sub>2</sub> DX				Draw-through AC fans 230/50/1							Connections		Stock model
	DT1 +2/-8 °C kW	SC2 kW	SC3 kW	SC4 kW	fan power nr. W	air throw m	sound pressure dB(A)	air flow m <sup>3</sup> /h	coil surface m <sup>2</sup>	Int. volume dm <sup>3</sup>	in mm	out mm		
Fin spacing 7 mm, fan speed H														
CCXH251 A 7	1.9	1.4	1.1	0.9	1	118	8.2	54	1307	5.2	1.1	8	10	-
CCXH251 B 7	2.5	1.9	1.5	1.2	1	118	7.9	54	1273	7.7	1.6	12	12	-
CCXH251 C 7	3.0	2.2	1.8	1.5	1	118	7.7	54	1242	10.3	2.2	12	12	-
CCXH252 A 7	3.6	2.7	2.1	1.8	2	236	11.8	57	2599	9.8	1.9	12	12	-
CCXH252 B 7	4.9	3.6	2.9	2.4	2	236	11.5	57	2526	14.7	2.8	12	12	-
CCXH252 C 7	5.9	4.4	3.5	2.9	2	236	11.1	57	2459	19.5	3.7	12	12	-
CCXH253 A 7	5.5	4.0	3.2	2.6	3	354	14.5	59	3891	14.4	2.6	12	12	-
CCXH253 B 7	7.3	5.4	4.3	3.6	3	354	14.1	59	3778	21.6	3.9	12	12	-
CCXH253 C 7	8.8	6.6	5.3	4.3	3	354	13.7	59	3675	28.7	5.2	16	12	-
CCXH254 A 7	7.2	5.3	4.2	3.5	4	472	16.9	60	5183	19.0	3.4	12	12	-
CCXH254 B 7	9.6	7.2	5.7	4.7	4	472	16.4	60	5030	28.5	5.1	12	12	-
CCXH351 A 7	3.6	2.7	2.1	1.7	1	184	13.9	49	2813	8.3	1.7	12	12	-
CCXH351 B 7	4.8	3.6	2.9	2.4	1	184	13.3	49	2702	12.4	2.6	12	12	-
CCXH351 C 7	5.8	4.3	3.5	2.9	1	184	12.8	49	2599	16.5	3.5	12	12	-
CCXH352 A 7	7.0	5.2	4.1	3.4	2	368	20.0	52	5579	15.6	3.0	12	12	-
CCXH352 B 7	9.4	7.0	5.6	4.6	2	368	19.1	52	5339	23.4	4.4	16	12	-
CCXH352 C 7	11.3	8.4	6.7	5.5	2	368	18.3	52	5117	31.3	5.9	16	12	-
CCXH353 A 7	10.5	7.7	6.1	5.0	3	552	24.6	54	8343	23.0	4.2	16	14	-
CCXH353 B 7	14.0	10.4	8.2	6.8	3	552	23.6	54	7973	34.5	6.3	16	14	-
CCXH353 C 7	16.9	12.5	10.0	8.0	3	552	22.5	54	7631	46.0	8.4	22	14	-
CCXH354 A 7	13.8	10.2	8.1	6.6	4	736	28.5	55	11110	30.4	5.4	16	14	-
CCXH354 B 7	18.7	13.8	11.0	8.8	4	736	27.3	55	10610	45.6	8.1	22	14	-
Fin spacing 7 mm, fan speed L														
CCXL251 A 7	1.3	1.0	0.8	0.7	1	45	4.8	34	777	5.2	1.1	8	10	-
CCXL251 B 7	1.8	1.3	1.0	0.9	1	45	4.7	34	758	7.7	1.6	12	12	-
CCXL251 C 7	2.1	1.6	1.3	1.0	1	45	4.6	34	741	10.3	2.2	12	12	-
CCXL252 A 7	2.6	1.9	1.6	1.3	2	90	7.0	37	1546	9.8	1.9	12	12	-
CCXL252 B 7	3.5	2.6	2.1	1.7	2	90	6.8	37	1506	14.7	2.8	12	12	-
CCXL252 C 7	4.1	3.0	2.5	2.0	2	90	6.7	37	1470	19.5	3.7	12	12	-
CCXL253 A 7	3.9	2.9	2.3	1.9	3	135	8.6	39	2315	14.4	2.6	12	12	-
CCXL253 B 7	5.2	3.8	3.1	2.5	3	135	8.4	39	2253	21.6	3.9	12	12	-
CCXL253 C 7	6.1	4.5	3.6	2.9	3	135	8.2	39	2198	28.7	5.2	16	12	-
CCXL254 A 7	5.2	3.8	3.1	2.5	4	180	10.0	40	3084	19.0	3.4	12	12	-
CCXL254 B 7	6.8	5.1	4.1	3.4	4	180	9.8	40	3000	28.5	5.1	12	12	-
CCXL351 A 7	2.8	2.0	1.6	1.3	1	65	9.0	42	1828	8.3	1.7	12	12	-
CCXL351 B 7	3.6	2.7	2.2	1.8	1	65	8.6	42	1736	12.4	2.6	12	12	-
CCXL351 C 7	4.3	3.2	2.6	2.1	1	65	8.2	42	1654	16.5	3.5	12	12	-
CCXL352 A 7	5.4	4.0	3.2	2.6	2	130	13.0	45	3617	15.6	3.0	12	12	-
CCXL352 B 7	7.1	5.2	4.2	3.5	2	130	12.3	45	3420	23.4	4.4	16	12	-
CCXL352 C 7	8.3	6.2	5.0	4.0	2	130	11.6	45	3245	31.3	5.9	16	12	-
CCXL353 A 7	8.0	5.9	4.7	3.7	3	195	16.0	47	5404	23.0	4.2	16	14	-
CCXL353 B 7	10.5	7.8	6.2	5.1	3	195	15.1	47	5101	34.5	6.3	16	14	-
CCXL353 C 7	12.3	9.1	7.0	5.7	3	195	14.3	47	4833	46.0	8.4	22	14	-
CCXL354 A 7	10.6	7.9	6.2	5.1	4	260	18.5	48	7191	30.4	5.4	16	14	-
CCXL354 B 7	13.9	10.3	8.0	6.5	4	260	17.4	48	6782	45.6	8.1	22	14	-

Model	Nominal capacities CO <sub>2</sub> DX		Draw-through EC fans 230/50/1							Connections		Stock model
	DT1 +2/-8 °C	SC2	nr.	fan	air	sound	air	coil	Int.	OD		
				power	throw	pressure	flow	surface	volume			
CCX	kW	kW		W	m	dB(A)	m <sup>3</sup> /h	m <sup>2</sup>	dm <sup>3</sup>	in mm	out mm	
Fin spacing 4 mm. fan speed H												
CCXHE251 A 4	2.6	1.9	1 70	8.0	52	1275	8.6	1.1	8	10		-
CCXHE251 B 4	3.4	2.5	1 70	7.7	52	1230	12.9	1.6	12	12		-
CCXHE251 C 4	3.8	2.8	1 70	7.4	52	1187	17.1	2.2	12	12		-
CCXHE252 A 4	5.0	3.8	2 140	11.5	55	2531	16.2	1.9	12	12		-
CCXHE252 B 4	6.5	4.8	2 140	11.0	55	2434	24.3	2.8	12	12		-
CCXHE252 C 4	7.4	5.5	2 140	10.6	55	2343	32.5	3.7	12	12		✓
CCXHE253 A 4	7.6	5.7	3 210	14.2	57	3787	23.9	2.6	12	12		-
CCXHE253 B 4	9.7	7.2	3 210	13.6	57	3637	35.8	3.9	12	12		-
CCXHE253 C 4	11.2	8.3	3 210	13.1	57	3496	47.8	5.2	16	12		-
CCXHE254 A 4	10.0	7.4	4 280	16.4	58	5042	31.5	3.4	12	12		-
CCXHE254 B 4	12.6	9.4	4 280	15.7	58	4840	47.3	5.1	12	12		-
CCXHE351 A 4	4.6	3.5	1 98	12.0	49	2433	13.7	1.7	12	12		✓
CCXHE351 B 4	5.9	4.4	1 98	11.3	49	2297	20.6	2.6	12	12		-
CCXHE351 C 4	6.7	5.0	1 98	10.7	49	2172	27.4	3.5	12	12		✓
CCXHE352 A 4	9.1	6.7	2 196	17.2	52	4811	26.0	3	12	12		✓
CCXHE352 B 4	11.6	8.6	2 196	16.2	52	4517	38.9	4.4	16	12		-
CCXHE352 C 4	13.1	9.8	2 196	15.2	52	4251	51.9	5.9	16	12		✓
CCXHE353 A 4	13.6	10.1	3 294	21.2	54	7186	38.2	4.2	16	14		-
CCXHE353 B 4	17.1	12.7	3 294	19.9	54	6735	57.3	6.3	16	14		-
CCXHE353 C 4	19.6	14.5	3 294	18.7	54	6326	76.4	8.4	22	14		✓
CCXHE354 A 4	17.9	13.3	4 392	24.6	55	9560	50.5	5.4	16	14		-
CCXHE354 B 4	22.9	17.0	4 392	23.0	55	8951	75.7	8.1	22	14		-
Fin spacing 4 mm. fan speed L												
CCXLE251 A 4	1.9	1.4	1 20	4.7	34	758	8.6	1.1	8	10		-
CCXLE251 B 4	2.3	1.7	1 20	4.6	34	733	12.9	1.6	12	12		-
CCXLE251 C 4	2.6	1.9	1 20	4.4	34	710	17.1	2.2	12	12		-
CCXLE252 A 4	3.7	2.7	2 40	6.8	37	1505	16.2	1.9	12	12		-
CCXLE252 B 4	4.6	3.4	2 40	6.6	37	1452	24.3	2.8	12	12		-
CCXLE252 C 4	5.1	3.8	2 40	6.4	37	1403	32.5	3.7	12	12		-
CCXLE253 A 4	5.5	4.1	3 60	8.4	39	2252	23.9	2.6	12	12		-
CCXLE253 B 4	6.8	5.1	3 60	8.1	39	2170	35.8	3.9	12	12		-
CCXLE253 C 4	7.6	5.7	3 60	7.8	39	2096	47.8	5.2	16	12		-
CCXLE254 A 4	7.3	5.4	4 80	9.7	40	2998	31.5	3.4	12	12		-
CCXLE254 B 4	9.0	6.7	4 80	9.4	40	2888	47.3	5.1	12	12		-
CCXLE351 A 4	3.8	2.8	1 58	8.6	42	1740	13.7	1.7	12	12		-
CCXLE351 B 4	4.7	3.5	1 58	8.0	42	1618	20.6	2.6	12	12		-
CCXLE351 C 4	5.2	3.9	1 58	7.5	42	1515	27.4	3.5	12	12		-
CCXLE352 A 4	7.4	5.5	2 116	12.3	45	3429	26.0	3	12	12		-
CCXLE352 B 4	9.2	6.8	2 116	11.4	45	3172	38.9	4.4	16	12		-
CCXLE352 C 4	10.1	7.5	2 116	10.6	45	2958	51.9	5.9	16	12		-
CCXLE353 A 4	11.1	8.2	3 174	15.1	47	5116	38.2	4.2	16	14		-
CCXLE353 B 4	13.5	10.1	3 174	14.0	47	4724	57.3	6.3	16	14		-
CCXLE353 C 4	15.0	11.2	3 174	13.0	47	4399	76.4	8.4	22	14		-
CCXLE354 A 4	14.7	10.9	4 232	17.5	48	6802	50.5	5.4	16	14		-
CCXLE354 B 4	18.1	13.4	4 232	16.1	48	6275	75.7	8.1	22	14		-

Model	Nominal capacities CO <sub>2</sub> DX				Draw-through EC fans 230/50/1							Connections		Stock model
	DT1 +2/-8 °C kW	SC2 kW	SC3 kW	SC4 kW	fan power nr.	air throw W	sound pressure dB(A)	air flow m <sup>3</sup> /h	coil surface m <sup>2</sup>	Int. volume dm <sup>3</sup>	in mm	out mm		
Fin spacing 7 mm, fan speed H														
CCXHE251 A 7	1.9	1.4	1.1	0.9	1	70	8.2	52	1307	5.2	1.1	8	10	-
CCXHE251 B 7	2.5	1.9	1.5	1.2	1	70	7.9	52	1273	7.7	1.6	12	12	-
CCXHE251 C 7	3.0	2.2	1.8	1.5	1	70	7.7	52	1242	10.3	2.2	12	12	✓
CCXHE252 A 7	3.6	2.7	2.1	1.8	2	140	11.8	55	2599	9.8	1.9	12	12	-
CCXHE252 B 7	4.9	3.6	2.9	2.4	2	140	11.5	55	2526	14.7	2.8	12	12	-
CCXHE252 C 7	5.9	4.4	3.5	2.9	2	140	11.1	55	2459	19.5	3.7	12	12	✓
CCXHE253 A 7	5.5	4.0	3.2	2.6	3	210	14.5	57	3891	14.4	2.6	12	12	-
CCXHE253 B 7	7.3	5.4	4.3	3.6	3	210	14.1	57	3778	21.6	3.9	12	12	-
CCXHE253 C 7	8.8	6.6	5.3	4.3	3	210	13.7	57	3675	28.7	5.2	16	12	-
CCXHE254 A 7	7.2	5.3	4.2	3.5	4	280	16.9	58	5183	19.0	3.4	12	12	-
CCXHE254 B 7	9.6	7.2	5.7	4.7	4	280	16.4	58	5030	28.5	5.1	12	12	-
CCXHE351 A 7	3.4	2.5	2.0	1.6	1	98	12.4	49	2524	8.3	1.7	12	12	-
CCXHE351 B 7	4.5	3.4	2.7	2.2	1	98	11.9	49	2423	12.4	2.6	12	12	-
CCXHE351 C 7	5.4	4.0	3.2	2.7	1	98	11.5	49	2329	16.5	3.5	12	12	-
CCXHE352 A 7	6.6	4.9	3.9	3.2	2	196	17.9	52	5005	15.6	3	12	12	-
CCXHE352 B 7	8.8	6.5	5.2	4.3	2	196	17.2	52	4787	23.4	4.4	16	12	✓
CCXHE352 C 7	10.5	7.8	6.3	5.2	2	196	16.4	52	4585	31.3	5.9	16	12	✓
CCXHE353 A 7	9.8	7.2	5.7	4.7	3	294	22.1	54	7484	23.0	4.2	16	14	-
CCXHE353 B 7	13.1	9.7	7.7	6.3	3	294	21.1	54	7148	34.5	6.3	16	14	-
CCXHE353 C 7	15.7	11.6	9.3	7.4	3	294	20.2	54	6837	46.0	8.4	22	14	✓
CCXHE354 A 7	13.0	9.6	7.6	6.2	4	392	25.6	55	9962	30.4	5.4	16	14	-
CCXHE354 B 7	17.4	12.9	10.3	8.2	4	392	24.4	55	9509	45.6	8.1	22	14	-
Fin spacing 7 mm, fan speed L														
CCXLE251 A 7	1.3	1.0	0.8	0.7	1	20	4.8	34	777	5.2	1.1	8	10	-
CCXLE251 B 7	1.8	1.3	1.0	0.9	1	20	4.7	34	758	7.7	1.6	12	12	-
CCXLE251 C 7	2.1	1.6	1.3	1.0	1	20	4.6	34	741	10.3	2.2	12	12	-
CCXLE252 A 7	2.6	1.9	1.6	1.3	2	40	7.0	37	1546	9.8	1.9	12	12	-
CCXLE252 B 7	3.5	2.6	2.1	1.7	2	40	6.8	37	1506	14.7	2.8	12	12	-
CCXLE252 C 7	4.1	3.0	2.5	2.0	2	40	6.7	37	1470	19.5	3.7	12	12	-
CCXLE253 A 7	3.9	2.9	2.3	1.9	3	60	8.6	39	2315	14.4	2.6	12	12	-
CCXLE253 B 7	5.2	3.8	3.1	2.5	3	60	8.4	39	2253	21.6	3.9	12	12	-
CCXLE253 C 7	6.1	4.5	3.6	2.9	3	60	8.2	39	2198	28.7	5.2	16	12	-
CCXLE254 A 7	5.2	3.8	3.1	2.5	4	80	10.0	40	3084	19.0	3.4	12	12	-
CCXLE254 B 7	6.8	5.1	4.1	3.4	4	80	9.8	40	3000	28.5	5.1	12	12	-
CCXLE351 A 7	2.8	2.0	1.6	1.3	1	58	9.0	42	1828	8.3	1.7	12	12	-
CCXLE351 B 7	3.6	2.7	2.2	1.8	1	58	8.6	42	1736	12.4	2.6	12	12	-
CCXLE351 C 7	4.3	3.2	2.6	2.1	1	58	8.2	42	1654	16.5	3.5	12	12	-
CCXLE352 A 7	5.4	4.0	3.2	2.6	2	116	13.0	45	3617	15.6	3	12	12	-
CCXLE352 B 7	7.1	5.2	4.2	3.5	2	116	12.3	45	3420	23.4	4.4	16	12	-
CCXLE352 C 7	8.3	6.2	5.0	4.0	2	116	11.6	45	3245	31.3	5.9	16	12	-
CCXLE353 A 7	8.0	5.9	4.7	3.7	3	174	16.0	47	5404	23.0	4.2	16	14	-
CCXLE353 B 7	10.5	7.8	6.2	5.1	3	174	15.1	47	5101	34.5	6.3	16	14	-
CCXLE353 C 7	12.3	9.1	7.0	5.7	3	174	14.3	47	4833	46.0	8.4	22	14	-
CCXLE354 A 7	10.6	7.9	6.2	5.1	4	232	18.5	48	7191	30.4	5.4	16	14	-
CCXLE354 B 7	13.9	10.3	8.0	6.5	4	232	17.4	48	6782	45.6	8.1	22	14	-

Model	Nominal capacities CO <sub>2</sub> DX		Draw-through AC fans 230-400/50/3							Connections		Stock model
	DT1 +2/-8 °C kW	SC2 kW	fan power nr.	air throw W	air throw m	sound pressure dB(A)	air flow m <sup>3</sup> /h	coil surface m <sup>2</sup>	Int. volume dm <sup>3</sup>	OD in mm	OD out mm	
Fin spacing 4 mm, fan speed H												
CCXH251 A 4	2.6	2.0	1	100	8.3	58	1325	8.6	1.1	8	10	-
CCXH251 B 4	3.5	2.6	1	100	8.0	58	1282	12.9	1.6	12	12	-
CCXH251 C 4	3.9	2.9	1	100	7.8	58	1243	17.1	2.2	12	12	-
CCXH252 A 4	5.2	3.8	2	200	11.9	61	2632	16.2	1.9	12	12	-
CCXH252 B 4	6.7	5.0	2	200	11.5	61	2541	24.3	2.8	12	12	-
CCXH252 C 4	7.7	5.7	2	200	11.1	61	2458	32.5	3.7	12	12	-
CCXH253 A 4	7.8	5.8	3	300	14.7	63	3938	23.9	2.6	12	12	-
CCXH253 B 4	10.0	7.4	3	300	14.2	63	3799	35.8	3.9	12	12	-
CCXH253 C 4	11.6	8.6	3	300	13.7	63	3670	47.8	5.2	16	12	-
CCXH254 A 4	10.2	7.6	4	400	17.1	64	5244	31.5	3.4	12	12	-
CCXH254 B 4	12.9	9.7	4	400	16.4	64	5056	47.3	5.1	12	12	-
CCXH351 A 4	4.8	3.6	1	170	12.6	48	2559	13.7	1.7	12	12	-
CCXH351 B 4	6.1	4.6	1	170	11.9	48	2423	20.6	2.6	12	12	-
CCXH351 C 4	7.0	5.2	1	170	11.3	48	2298	27.4	3.5	12	12	-
CCXH352 A 4	9.3	6.9	2	340	18.1	51	5062	26.0	3.0	12	12	-
CCXH352 B 4	12.0	8.9	2	340	17.1	51	4770	38.9	4.4	16	12	-
CCXH352 C 4	13.6	10.2	2	340	16.1	51	4501	51.9	5.9	16	12	-
CCXH353 A 4	14.0	10.4	3	510	22.3	53	7562	38.2	4.2	16	14	-
CCXH353 B 4	17.6	13.1	3	510	21.0	53	7114	57.3	6.3	16	14	-
CCXH353 C 4	20.4	15.1	3	510	19.8	53	6701	76.4	8.4	22	14	-
CCXH354 A 4	18.4	13.6	4	680	25.9	54	10060	50.5	5.4	16	14	-
CCXH354 B 4	23.7	17.6	4	680	24.3	54	9457	75.7	8.1	22	14	-



Model	Nominal capacities CO <sub>2</sub> DX		Draw-through AC fans 230-400/50/3						Connections		Stock model	
	DT1 +2/-8 °C kW	SC2 kW	fan power nr.	air throw W	air throw m	sound pressure dB(A)	air flow m <sup>3</sup> /h	coil surface m <sup>2</sup>	Int. volume dm <sup>3</sup>	OD in mm		OD out mm
Fin spacing 4 mm. fan speed H												
CCXH401 A 4	6.4	4.8	1	280	16.6	53	3777	17.4	2.1	12	10	-
CCXH401 B 4	8.3	6.2	1	280	15.5	53	3528	26.0	3.2	12	10	-
CCXH401 C 4	9.1	6.8	1	280	14.5	53	3307	34.7	4.3	12	12	-
CCXH402 A 4	12.7	9.5	2	560	23.6	56	7509	33.9	3.8	12	12	-
CCXH402 B 4	16.4	12.2	2	560	21.9	56	6997	50.8	5.7	16	14	-
CCXH402 C 4	18.8	14.1	2	560	20.5	56	6546	67.8	7.6	16	14	-
CCXH403 A 4	18.9	14.1	3	840	28.9	58	11240	50.4	5.5	16	16	-
CCXH403 B 4	24.5	18.3	3	840	26.9	58	10470	75.6	8.2	16	16	-
CCXH403 C 4	26.9	20.3	3	840	25.2	58	9783	100.8	10.9	16	16	-
CCXH404 A 4	25.6	19.1	4	1120	33.4	59	14970	67.0	7.1	16	16	-
CCXH404 B 4	30.9	23.3	4	1120	31.1	59	13930	100.4	10.7	16	16	-
CCXH404 C 4	35.8	27.0	4	1120	29.1	59	13020	133.9	14.3	22	16	-
CCXH501 A 4	12.4	9.3	1	720	23.9	55	7447	32.3	3.8	12	12	-
CCXH501 B 4	16.3	12.2	1	720	22.8	55	7097	48.5	5.7	16	12	-
CCXH501 C 4	19.0	14.2	1	720	21.8	55	6782	64.7	7.6	16	12	-
CCXH502 A 4	23.1	17.5	2	1440	34.0	58	14850	63.6	6.9	16	16	-
CCXH502 B 4	29.7	22.5	2	1440	32.4	58	14140	95.3	10.4	16	16	-
CCXH502 C 4	36.2	27.3	2	1440	30.9	58	13490	127.1	13.8	22	16	-
CCXH503 A 4	36.9	27.5	3	2160	41.7	60	22250	94.8	10.1	22	16	-
CCXH503 B 4	44.5	33.7	3	2160	39.7	60	21170	142.2	15.1	22	16	-
CCXH503 C 4	52.7	39.9	3	2160	37.9	60	20200	189.6	20.1	22	18	-
CCXH504 A 4	46.2	34.8	4	2880	48.2	61	29660	126.0	13.2	22	18	-
CCXH504 B 4	61.3	46.2	4	2880	45.9	61	28210	189.0	19.8	22	22	-
Fin spacing 4 mm. fan speed L												
CCXL401 A 4	4.9	3.6	1	120	10.1	43	2295	17.4	2.1	12	10	-
CCXL401 B 4	6.1	4.5	1	120	9.4	43	2135	26.0	3.2	12	10	-
CCXL401 C 4	6.5	4.9	1	120	8.7	43	1995	34.7	4.3	12	12	-
CCXL402 A 4	9.6	7.2	2	240	14.3	46	4562	33.9	3.8	12	12	-
CCXL402 B 4	12.0	8.9	2	240	13.3	46	4232	50.8	5.7	16	14	-
CCXL402 C 4	13.3	9.9	2	240	12.4	46	3946	67.8	7.6	16	14	-
CCXL403 A 4	14.4	10.8	3	360	17.6	48	6828	50.4	5.5	16	16	-
CCXL403 B 4	17.9	13.4	3	360	16.3	48	6328	75.6	8.2	16	16	-
CCXL403 C 4	19.3	14.5	3	360	15.2	48	5897	100.8	10.9	16	16	-
CCXL404 A 4	19.4	14.4	4	480	20.3	49	9094	67.0	7.1	16	16	-
CCXL404 B 4	23.1	17.3	4	480	18.8	49	8425	100.4	10.7	16	16	-
CCXL404 C 4	25.7	19.3	4	480	17.5	49	7848	133.9	14.3	22	16	-
CCXL501 A 4	9.9	7.4	1	290	15.7	45	4880	32.3	3.8	12	12	-
CCXL501 B 4	12.6	9.4	1	290	15.0	45	4656	48.5	5.7	16	12	-
CCXL501 C 4	14.3	10.7	1	290	14.3	45	4447	64.7	7.6	16	12	-
CCXL502 A 4	18.8	14.1	2	580	22.3	48	9732	63.6	6.9	16	16	-
CCXL502 B 4	23.6	17.8	2	580	21.2	48	9274	95.3	10.4	16	16	-
CCXL502 C 4	27.7	20.8	2	580	20.3	48	8846	127.1	13.8	22	16	-
CCXL503 A 4	29.3	21.9	3	870	27.3	50	14580	94.8	10.1	22	16	-
CCXL503 B 4	35.4	26.7	3	870	26.1	50	13890	142.2	15.1	22	16	-
CCXL503 C 4	40.7	30.6	3	870	24.8	50	13240	189.6	20.1	22	18	-
CCXL504 A 4	37.5	28.2	4	1160	31.6	51	19430	126.0	13.2	22	18	-
CCXL504 B 4	48.2	36.2	4	1160	30.1	51	18510	189.0	19.8	22	22	-

Model	Nominal capacities CO <sub>2</sub> DX				Draw-through AC fans 230-400/50/3							Connections		Stock model
	DT1 +2/-8 °C	SC2	SC3	SC4	fan power nr.	air throw W	sound pressure dB(A)	air flow m <sup>3</sup> /h	coil surface m <sup>2</sup>	Int. volume dm <sup>3</sup>	OD in mm	OD out mm		
CCX	kW	kW	kW	kW										
Fin spacing 7 mm, fan speed H														
CCXH251 A 7	1.9	1.4	1.1	0.9	1	100	8.5	58	1356	5.2	1.1	8	10	-
CCXH251 B 7	2.6	1.9	1.5	1.3	1	100	8.2	58	1322	7.7	1.6	12	12	-
CCXH251 C 7	3.1	2.3	1.9	1.5	1	100	8.1	58	1293	10.3	2.2	12	12	-
CCXH252 A 7	3.7	2.8	2.2	1.8	2	200	12.2	61	2697	9.8	1.9	12	12	-
CCXH252 B 7	5.0	3.7	3.0	2.5	2	200	11.9	61	2626	14.7	2.8	12	12	-
CCXH252 C 7	6.1	4.5	3.6	3.0	2	200	11.6	61	2563	19.5	3.7	12	12	-
CCXH253 A 7	5.6	4.1	3.3	2.7	3	300	15.1	63	4038	14.4	2.6	12	12	-
CCXH253 B 7	7.5	5.6	4.5	3.7	3	300	14.7	63	3929	21.6	3.9	12	12	-
CCXH253 C 7	9.1	6.7	5.4	4.4	3	300	14.3	63	3833	28.7	5.2	16	12	-
CCXH254 A 7	7.4	5.5	4.3	3.5	4	400	17.5	64	5378	19.0	3.4	12	12	-
CCXH254 B 7	9.8	7.3	5.8	4.8	4	400	17.0	64	5232	28.5	5.1	12	12	-
CCXH351 A 7	3.5	2.6	2.0	1.7	1	170	13.1	48	2656	8.3	1.7	12	12	-
CCXH351 B 7	4.7	3.5	2.8	2.3	1	170	12.6	48	2548	12.4	2.6	12	12	-
CCXH351 C 7	5.6	4.2	3.3	2.7	1	170	12.1	48	2453	16.5	3.5	12	12	-
CCXH352 A 7	6.8	5.0	4.0	3.3	2	340	18.9	51	5264	15.6	3.0	12	12	-
CCXH352 B 7	9.1	6.8	5.4	4.4	2	340	18.0	51	5036	23.4	4.4	16	12	-
CCXH352 C 7	10.9	8.1	6.5	5.4	2	340	17.3	51	4834	31.3	5.9	16	12	-
CCXH353 A 7	10.1	7.5	5.9	4.9	3	510	23.2	53	7870	23.0	4.2	16	14	-
CCXH353 B 7	13.5	10.0	8.0	6.5	3	510	22.2	53	7521	34.5	6.3	16	14	-
CCXH353 C 7	16.3	12.1	9.7	7.7	3	510	21.3	53	7211	46.0	8.4	22	14	-
CCXH354 A 7	13.3	9.9	7.8	6.4	4	680	26.9	54	10480	30.4	5.4	16	14	-
CCXH354 B 7	18.0	13.3	10.6	8.5	4	680	25.7	54	10010	45.6	8.1	22	14	-

Model	Nominal capacities CO <sub>2</sub> DX				Draw-through AC fans 230-400/50/3							Connections		Stock model
	DT1 +2/-8 °C kW	SC2 kW	SC3 kW	SC4 kW	fan power nr. W	air throw m	sound pressure dB(A)	air flow m <sup>3</sup> /h	coil surface m <sup>2</sup>	Int. volume dm <sup>3</sup>	in mm	OD out mm		
Fin spacing 7 mm, fan speed H														
CCXH401 A 7	4.7	3.5	2.8	2.2	1	280	17.3	53	3942	10.5	2.1	12	10	-
CCXH401 B 7	6.4	4.8	3.8	3.1	1	280	16.4	53	3750	15.7	3.2	12	10	-
CCXH401 C 7	7.5	5.6	4.4	3.6	1	280	15.7	53	3578	20.9	4.3	12	12	-
CCXH402 A 7	9.4	7.0	5.5	4.5	2	560	24.6	56	7848	20.4	3.8	12	12	-
CCXH402 B 7	12.7	9.4	7.5	6.1	2	560	23.4	56	7454	30.6	5.7	16	14	-
CCXH402 C 7	15.3	11.4	9.0	7.4	2	560	22.3	56	7098	40.8	7.6	16	14	-
CCXH403 A 7	14.1	10.5	8.2	6.7	3	840	30.2	58	11750	30.4	5.5	16	16	-
CCXH403 B 7	19.0	14.1	11.1	9.1	3	840	28.7	58	11160	45.5	8.2	16	16	-
CCXH403 C 7	22.2	16.6	13.0	10.6	3	840	27.3	58	10620	60.7	10.9	16	16	-
CCXH404 A 7	18.9	14.0	11.0	9.0	4	1120	34.9	59	15660	40.3	7.1	16	16	-
CCXH404 B 7	24.5	18.3	14.2	11.5	4	1120	33.2	59	14860	60.5	10.7	16	16	-
CCXH404 C 7	29.5	22.1	17.3	14.1	4	1120	31.5	59	14140	80.6	14.3	22	16	-
CCXH501 A 7	9.1	6.8	5.3	4.3	1	720	24.6	55	7673	19.5	3.8	12	12	-
CCXH501 B 7	12.5	9.3	7.3	6.0	1	720	23.8	55	7408	29.2	5.7	16	12	-
CCXH501 C 7	15.1	11.3	8.9	7.3	1	720	23.0	55	7163	38.9	7.6	16	12	-
CCXH502 A 7	17.5	13.1	10.1	8.2	2	1440	35.1	58	15310	38.3	6.9	16	16	-
CCXH502 B 7	23.5	17.7	13.6	11.0	2	1440	33.8	58	14770	57.4	10.4	16	16	-
CCXH502 C 7	29.3	21.9	17.2	14.0	2	1440	32.7	58	14270	76.5	13.8	22	16	-
CCXH503 A 7	27.1	20.1	15.8	12.9	3	2160	43.0	60	22950	57.1	10.1	22	16	-
CCXH503 B 7	35.2	26.4	20.4	16.4	3	2160	41.5	60	22130	85.6	15.1	22	16	-
CCXH503 C 7	43.0	32.3	25.1	20.3	3	2160	40.1	60	21370	114.1	20.1	22	18	-
CCXH504 A 7	34.9	26.1	20.2	16.3	4	2880	49.7	61	30590	75.8	13.2	22	18	-
CCXH504 B 7	47.9	35.8	27.9	22.6	4	2880	48.0	61	29490	113.8	19.8	22	22	-
Fin spacing 7 mm, fan speed L														
CCXL401 A 7	3.6	2.6	2.1	1.7	1	120	10.6	43	2409	10.5	2.1	12	10	-
CCXL401 B 7	4.7	3.5	2.8	2.3	1	120	10.0	43	2290	15.7	3.2	12	10	-
CCXL401 C 7	5.4	4.1	3.2	2.6	1	120	9.6	43	2180	20.9	4.3	12	12	-
CCXL402 A 7	7.0	5.2	4.1	3.4	2	240	15.0	46	4797	20.4	3.8	12	12	-
CCXL402 B 7	9.3	6.9	5.5	4.5	2	240	14.3	46	4550	30.6	5.7	16	14	-
CCXL402 C 7	10.9	8.1	6.5	5.4	2	240	13.6	46	4325	40.8	7.6	16	14	-
CCXL403 A 7	10.5	7.8	6.2	5.1	3	360	18.5	48	7184	30.4	5.5	16	16	-
CCXL403 B 7	13.9	10.3	8.2	6.8	3	360	17.5	48	6809	45.5	8.2	16	16	-
CCXL403 C 7	16.1	12.0	9.6	7.8	3	360	16.6	48	6469	60.7	10.9	16	16	-
CCXL404 A 7	14.1	10.4	8.3	6.8	4	480	21.4	49	9571	40.3	7.1	16	16	-
CCXL404 B 7	18.2	13.6	10.7	8.7	4	480	20.2	49	9068	60.5	10.7	16	16	-
CCXL404 C 7	21.4	16.0	12.7	10.5	4	480	19.2	49	8612	80.6	14.3	22	16	-
CCXL501 A 7	7.1	5.3	4.2	3.4	1	290	16.2	45	5044	19.5	3.8	12	12	-
CCXL501 B 7	9.6	7.1	5.7	4.7	1	290	15.6	45	4868	29.2	5.7	16	12	-
CCXL501 C 7	11.4	8.5	6.8	5.6	1	290	15.1	45	4715	38.9	7.6	16	12	-
CCXL502 A 7	13.9	10.3	8.1	6.6	2	580	23.1	48	10060	38.3	6.9	16	16	-
CCXL502 B 7	18.4	13.8	10.8	8.8	2	580	22.2	48	9707	57.4	10.4	16	16	-
CCXL502 C 7	22.4	16.7	13.3	10.9	2	580	21.5	48	9393	76.5	13.8	22	16	-
CCXL503 A 7	21.2	15.7	12.5	10.2	3	870	28.3	50	15090	57.1	10.1	22	16	-
CCXL503 B 7	27.6	20.6	16.2	13.2	3	870	27.3	50	14540	85.6	15.1	22	16	-
CCXL503 C 7	33.2	24.8	19.6	16.1	3	870	26.4	50	14070	114.1	20.1	22	18	-
CCXL504 A 7	27.7	20.6	16.2	13.2	4	1160	32.7	51	20110	75.8	13.2	22	18	-
CCXL504 B 7	37.2	27.8	22.0	18.0	4	1160	31.5	51	19380	113.8	19.8	22	22	-

Model	Nominal capacities HFC DX			Blow-through AC fans 230/50/1							Connections		Stock model
	DT1 +2/-8 °C	SC1	SC2	fan power nr.	air throw W	sound pressure dB(A)	air flow m <sup>3</sup> /h	coil surface m <sup>2</sup>	Int. volume dm <sup>3</sup>	in mm	out mm		
CCBE	kW	kW	kW										
Fin spacing 4 mm, fan speed H													
CCBEH301 A 4	<b>2.9</b>	3.2	2.1	1	72	7.2	42	1201	9.0	2.0	12	16	-
CCBEH301 B 4	<b>3.5</b>	3.8	2.6	1	72	6.7	42	1120	13.5	3.1	12	16	-
CCBEH301 C 4	<b>3.8</b>	4.1	2.8	1	72	6.3	42	1052	18.0	4.1	16	18	-
CCBEH302 A 4	<b>5.8</b>	6.3	4.3	2	144	10.2	45	2403	18.0	3.6	16	18	-
CCBEH302 B 4	<b>6.8</b>	7.5	5.1	2	144	9.5	45	2240	27.0	5.4	16	18	-
CCBEH302 C 4	<b>7.6</b>	8.2	5.6	2	144	9.0	45	2104	36.0	7.2	22	28	-
CCBEH303 A 4	<b>8.7</b>	9.4	6.4	3	216	12.5	47	3604	27.0	5.2	22	28	-
CCBEH303 B 4	<b>10.4</b>	11.4	7.8	3	216	11.7	47	3360	40.5	7.8	22	28	-
CCBEH303 C 4	<b>11.2</b>	12.3	8.4	3	216	11.0	47	3157	54.1	10.4	22	28	-
CCBEH304 A 4	<b>11.5</b>	12.6	8.6	4	288	14.5	48	4806	36.0	6.7	22	28	-
CCBEH304 B 4	<b>13.5</b>	15.0	10.2	4	288	13.5	48	4480	54.1	10.1	22	28	-
CCBEH351 A 4	<b>5.1</b>	5.7	3.8	1	180	11.3	49	2362	14.4	3.1	12	16	-
CCBEH351 B 4	<b>6.4</b>	7.1	4.8	1	180	10.6	49	2225	21.6	4.7	16	18	-
CCBEH351 C 4	<b>7.1</b>	7.8	5.3	1	180	10.0	49	2106	28.8	6.3	16	22	-
CCBEH352 A 4	<b>10.3</b>	11.4	7.7	2	360	15.9	52	4725	28.8	5.6	16	22	-
CCBEH352 B 4	<b>11.9</b>	13.5	9.0	2	360	15.0	52	4451	43.3	8.5	16	22	-
CCBEH352 C 4	<b>14.3</b>	15.6	10.7	2	360	14.2	52	4212	57.7	11.3	22	28	-
CCBEH353 A 4	<b>15.8</b>	17.3	11.7	3	540	19.5	54	7087	43.3	8.1	22	28	-
CCBEH353 B 4	<b>19.0</b>	21.1	14.3	3	540	18.4	54	6676	64.9	12.2	22	28	-
CCBEH353 C 4	<b>20.3</b>	22.8	15.4	3	540	17.4	54	6318	86.5	16.3	22	28	-
CCBEH354 A 4	<b>20.6</b>	22.9	15.4	4	720	22.5	55	9449	57.7	10.7	22	28	-
CCBEH354 B 4	<b>23.7</b>	27.1	18.1	4	720	21.2	55	8902	86.5	16.0	22	28	-

Model	Nominal capacities HFC DX			Blow-through AC fans 230/50/1							Connections		Stock model
	DT1 +2/-8 °C	SC1	SC2	fan power nr.	air throw W	sound pressure dB(A)	air flow m <sup>3</sup> /h	coil surface m <sup>2</sup>	Int. volume dm <sup>3</sup>	in mm	out mm		
CCBE	kW	kW	kW										
Fin spacing 4 mm, fan speed L													
CCBEL351 A 4	<b>3.9</b>	4.3	2.9	1	74	7.18	38	1509	14.4	3.1	12	16	-
CCBEL351 B 4	<b>4.7</b>	5.1	3.5	1	74	6.72	38	1412	21.6	4.7	16	18	-
CCBEL351 C 4	<b>5.0</b>	5.4	3.7	1	74	6.33	38	1329	28.8	6.3	16	22	-
CCBEL352 A 4	<b>7.8</b>	8.6	5.8	2	148	10.16	41	3017	28.8	5.6	16	22	-
CCBEL352 B 4	<b>8.9</b>	10.0	6.8	2	148	9.51	41	2824	43.3	8.5	16	22	-
CCBEL352 C 4	<b>10.0</b>	10.9	7.5	2	148	8.95	41	2658	57.7	11.3	22	28	-
CCBEL353 A 4	<b>11.8</b>	12.8	8.7	3	222	12.44	43	4526	43.3	8.1	22	28	-
CCBEL353 B 4	<b>13.9</b>	15.2	10.4	3	222	11.65	43	4236	64.9	12.2	22	28	-
CCBEL353 C 4	<b>14.6</b>	16.1	11.0	3	222	10.96	43	3987	86.5	16.3	22	28	-
CCBEL354 A 4	<b>15.6</b>	17.2	11.6	4	296	14.37	44	6034	57.7	10.7	22	28	-
CCBEL354 B 4	<b>17.9</b>	19.9	13.5	4	296	13.45	44	5648	86.5	16.0	22	28	-

Model	Nominal capacities HFC DX				Blow-through AC fans 230/50/1							Connections		Stock model
	DT1 +2/-8 °C	SC2	SC3	SC4	fan power nr.	air throw W	sound pressure dB(A)	air flow m <sup>3</sup> /h	coil surface m <sup>2</sup>	Int. volume dm <sup>3</sup>	in mm	out mm		
CCBE	kW	kW	kW	kW										
Fin spacing 7 mm, fan speed H														
CCBEH301 A 7	2.2	1.6	1.3	1.0	1	72	7.59	42	1261	5.5	2.0	12	16	-
CCBEH301 B 7	2.8	2.1	1.7	1.4	1	72	7.19	42	1193	8.2	3.1	12	16	-
CCBEH301 C 7	3.2	2.4	1.9	1.6	1	72	6.84	42	1136	11.0	4.1	16	18	-
CCBEH302 A 7	4.3	3.2	2.5	2.1	2	144	10.74	45	2521	11.0	3.6	16	18	-
CCBEH302 B 7	5.5	4.1	3.3	2.6	2	144	10.16	45	2386	16.4	5.4	16	18	-
CCBEH302 C 7	6.5	4.8	3.9	3.2	2	144	9.68	45	2272	21.9	7.2	22	28	-
CCBEH303 A 7	6.5	4.8	3.8	3.1	3	216	13.15	47	3782	16.4	5.2	22	28	-
CCBEH303 B 7	8.4	6.2	5.0	4.1	3	216	12.44	47	3578	24.7	7.8	22	28	-
CCBEH303 C 7	9.6	7.2	5.7	4.7	3	216	11.85	47	3408	32.9	10.4	22	28	-
CCBEH304 A 7	8.7	6.4	5.1	4.2	4	288	15.19	48	5043	21.9	6.7	22	28	-
CCBEH304 B 7	11.1	8.3	6.5	5.3	4	288	14.37	48	4771	32.9	10.1	22	28	-
CCBEH351 A 7	3.9	2.9	2.3	1.9	1	180	11.68	49	2454	8.8	3.1	12	16	-
CCBEH351 B 7	5.2	3.8	3.0	2.5	1	180	11.17	49	2345	13.2	4.7	16	18	-
CCBEH351 C 7	6.0	4.5	3.6	2.9	1	180	10.71	49	2249	17.5	6.3	16	22	-
CCBEH352 A 7	7.9	5.8	4.6	3.7	2	360	16.52	52	4907	17.5	5.6	16	22	-
CCBEH352 B 7	9.9	7.4	5.7	4.6	2	360	15.79	52	4690	26.3	8.5	16	22	-
CCBEH352 C 7	12.1	9.0	7.2	5.9	2	360	15.15	52	4498	35.1	11.3	22	28	-
CCBEH353 A 7	11.9	8.8	6.9	5.7	3	540	20.24	54	7361	26.3	8.1	22	28	-
CCBEH353 B 7	15.4	11.5	9.0	7.3	3	540	19.34	54	7035	39.4	12.2	22	28	-
CCBEH353 C 7	17.5	13.2	10.3	8.3	3	540	18.55	54	6747	52.6	16.3	22	28	-
CCBEH354 A 7	15.7	11.7	9.2	7.5	4	720	23.37	55	9814	35.1	10.7	22	28	-
CCBEH354 B 7	19.8	14.9	11.5	9.1	4	720	22.34	55	9381	52.6	16.0	22	28	-

Model	Nominal capacities HFC DX				Blow-through AC fans 230/50/1							Connections		Stock model
	DT1 +2/-8 °C	SC2	SC3	SC4	fan power nr.	air throw W	sound pressure m	air flow dB(A)	coil surface m <sup>3</sup> /h	coil surface m <sup>2</sup>	Int. volume dm <sup>3</sup>	OD in mm	OD out mm	
CCBE	kW	kW	kW	kW										
Fin spacing 7 mm, fan speed L														
CCBEL351 A 7	<b>2.9</b>	2.2	1.7	1.4	1	74	7.5	38	1578	8.8	3.1	12	16	-
CCBEL351 B 7	<b>3.8</b>	2.8	2.2	1.8	1	74	7.1	38	1501	13.2	4.7	16	18	-
CCBEL351 C 7	<b>4.3</b>	3.2	2.6	2.1	1	74	6.8	38	1434	17.5	6.3	16	18	-
CCBEL352 A 7	<b>5.9</b>	4.4	3.5	2.8	2	148	10.6	41	3156	17.5	5.6	16	22	-
CCBEL352 B 7	<b>7.4</b>	5.5	4.4	3.5	2	148	10.1	41	3002	26.3	8.5	16	22	-
CCBEL352 C 7	<b>8.6</b>	6.4	5.2	4.3	2	148	9.7	41	2867	35.1	11.3	16	22	-
CCBEL353 A 7	<b>8.8</b>	6.5	5.2	4.3	3	222	13.0	43	4734	26.3	8.1	16	18	-
CCBEL353 B 7	<b>11.3</b>	8.4	6.7	5.5	3	222	12.4	43	4503	39.4	12.2	16	22	-
CCBEL353 C 7	<b>12.8</b>	9.6	7.6	6.2	3	222	11.8	43	4301	52.6	16.3	16	22	-
CCBEL354 A 7	<b>11.8</b>	8.7	6.9	5.7	4	296	15.0	44	6312	35.1	10.7	16	22	-
CCBEL354 B 7	<b>14.8</b>	11.1	8.7	7.1	4	296	14.3	44	6003	52.6	16.0	16	35	-

Model	Nominal capacities HFC DX			Blow-through AC fans 400/50/3							Connections		Stock model
	DT1 +2/-8 °C	SC1	SC2	fan power nr.	air throw W	sound pressure dB(A)	air flow m <sup>3</sup> /h	coil surface m <sup>2</sup>	Int. volume dm <sup>3</sup>	OD in mm	OD out mm		
CCBE	kW	kW	kW										
Fin spacing 4 mm, fan speed H													
CCBEH301 A 4	<b>2.8</b>	3.1	2.1	1	68	7.0	42	1154	9.0	2.0	12	16	-
CCBEH301 B 4	<b>3.4</b>	3.7	2.5	1	68	6.5	42	1074	13.5	3.1	12	16	-
CCBEH301 C 4	<b>3.7</b>	4.0	2.7	1	68	6.1	42	1007	18.0	4.1	16	18	-
CCBEH302 A 4	<b>5.6</b>	6.1	4.2	2	136	9.8	45	2309	18.0	3.6	16	18	-
CCBEH302 B 4	<b>6.6</b>	7.3	4.9	2	136	9.1	45	2148	27.0	5.4	16	18	-
CCBEH302 C 4	<b>7.3</b>	7.9	5.4	2	136	8.6	45	2015	36.0	7.2	22	28	-
CCBEH303 A 4	<b>8.4</b>	9.1	6.2	3	204	12.0	47	3463	27.0	5.2	22	28	-
CCBEH303 B 4	<b>10.1</b>	11.0	7.5	3	204	11.2	47	3222	40.5	7.8	22	28	-
CCBEH303 C 4	<b>10.8</b>	11.9	8.1	3	204	10.5	47	3022	54.1	10.4	22	28	-
CCBEH304 A 4	<b>11.2</b>	12.3	8.3	4	272	13.9	48	4618	36.0	6.7	22	28	-
CCBEH304 B 4	<b>13.2</b>	14.6	9.9	4	272	12.9	48	4296	54.1	10.1	22	28	-
CCBEH351 A 4	<b>5.1</b>	5.6	3.8	1	170	11.0	48	2311	14.4	3.1	12	16	-
CCBEH351 B 4	<b>6.3</b>	7.0	4.7	1	170	10.4	48	2178	21.6	4.7	16	18	-
CCBEH351 C 4	<b>7.0</b>	7.7	5.3	1	170	9.8	48	2062	28.8	6.3	16	22	-
CCBEH352 A 4	<b>10.2</b>	11.3	7.6	2	340	15.6	51	4621	28.8	5.6	16	22	-
CCBEH352 B 4	<b>11.7</b>	13.3	8.9	2	340	14.7	51	4356	43.3	8.5	16	22	-
CCBEH352 C 4	<b>14.1</b>	15.4	10.5	2	340	13.9	51	4123	57.7	11.3	22	28	-
CCBEH353 A 4	<b>15.6</b>	17.0	11.5	3	510	19.1	53	6932	43.3	8.1	22	28	-
CCBEH353 B 4	<b>18.8</b>	20.8	14.1	3	510	18.0	53	6534	64.9	12.2	22	28	-
CCBEH353 C 4	<b>20.0</b>	22.4	15.2	3	510	17.0	53	6185	86.5	16.3	22	28	-
CCBEH354 A 4	<b>20.3</b>	22.6	15.2	4	680	22.0	54	9243	57.7	10.7	22	28	-
CCBEH354 B 4	<b>23.5</b>	26.7	17.9	4	680	20.7	54	8711	86.5	16.0	22	28	-



Model	Nominal capacities HFC DX			Blow-through AC fans 400/50/3							Connections		Stock model
	DT1 +2/-8 °C	SC1	SC2	fan power nr.	air throw W	sound pressure dB(A)	air flow m <sup>3</sup> /h	coil surface m <sup>2</sup>	Int. volume dm <sup>3</sup>	OD in mm	OD out mm		
CCBE	kW	kW	kW										
Fin spacing 4 mm, fan speed H													
CCBEH401 A 4	6.5	7.1	4.8	1	229	13.8	55	3070	16.2	3.5	16	18	-
CCBEH401 B 4	7.8	8.7	5.8	1	229	12.9	55	2873	24.3	5.3	16	18	-
CCBEH401 C 4	8.8	9.7	6.6	1	229	12.1	55	2699	32.4	7.0	16	22	-
CCBEH402 A 4	12.6	14.0	9.4	2	458	19.5	58	6139	32.4	6.3	16	22	-
CCBEH402 B 4	14.4	16.5	11.0	2	458	18.2	58	5746	48.7	9.5	16	22	-
CCBEH402 C 4	17.7	19.4	13.2	2	458	17.1	58	5399	64.9	12.7	22	35	-
CCBEH403 A 4	19.4	21.3	14.4	3	687	23.9	60	9209	48.7	9.2	22	28	-
CCBEH403 B 4	23.3	26.0	17.5	3	687	22.3	60	8619	73.0	13.8	22	28	-
CCBEH403 C 4	24.8	28.0	18.8	3	687	21.0	60	8098	97.3	18.4	22	28	-
CCBEH404 A 4	25.1	28.1	18.8	4	916	27.6	61	12280	64.9	12.0	22	28	-
CCBEH404 B 4	28.8	33.1	22.0	4	916	25.8	61	11490	97.3	18.0	22	28	-
CCBEH404 C 4	33.1	37.4	25.1	4	916	24.2	61	10800	129.7	24.0	22	35	-
CCBEH501 A 4	13.5	15.2	10.1	1	720	21.5	55	6594	49.9	11.1	16	35	-
CCBEH501 B 4	17.2	19.0	12.8	1	720	20.0	55	6123	74.8	16.7	22	35	-
CCBEH501 C 4	18.5	20.7	13.9	1	720	18.7	55	5730	99.8	22.3	22	42	-
CCBEH502 A 4	25.6	29.5	19.4	2	1440	30.5	58	13190	99.8	20.4	22	42	-
CCBEH502 B 4	34.1	37.9	25.4	2	1440	28.3	58	12250	149.7	30.5	28	42	-
CCBEH502 C 4	37.1	41.4	27.9	2	1440	26.5	58	11460	199.5	40.8	28	42	-
CCBEH503 A 4	41.5	46.3	30.9	3	2160	37.3	60	19780	149.7	29.6	28	42	-
CCBEH503 B 4	45.0	52.5	34.6	3	2160	34.6	60	18370	224.5	44.4	28	42	-
CCBEH503 C 4	55.7	62.2	41.9	3	2160	32.4	60	17190	299.3	59.2	28	42	-
CCBEH504 A 4	56.2	62.0	41.4	4	2880	43.1	61	26370	199.5	38.8	28	54	-
CCBEH504 B 4	65.5	74.2	49.5	4	2880	40.0	61	24490	299.3	58.3	28	54	-
CCBEH504 C 4	74.3	83.0	55.9	4	2880	37.4	61	22920	399.1	77.7	28	54	-
Fin spacing 4 mm, fan speed L													
CCBEL501 A 4	10.6	11.8	7.9	1	260	14.2	47	4342	49.9	11.1	16	35	-
CCBEL501 B 4	12.9	14.1	9.5	1	260	13.2	47	4029	74.8	16.7	22	35	-
CCBEL501 C 4	13.7	15.1	10.3	1	260	12.3	47	3767	99.8	22.3	22	42	-
CCBEL502 A 4	20.6	23.1	15.5	2	520	20.1	50	8683	99.8	20.4	22	42	-
CCBEL502 B 4	25.7	28.2	19.1	2	520	18.6	50	8058	149.7	30.5	28	42	-
CCBEL502 C 4	27.6	30.3	20.6	2	520	17.4	50	7534	199.5	40.8	28	42	-
CCBEL503 A 4	32.2	35.4	23.8	3	780	24.6	52	13030	149.7	29.6	28	42	-
CCBEL503 B 4	35.9	40.7	27.2	3	780	22.8	52	12090	224.5	44.4	28	42	-
CCBEL503 C 4	41.4	45.4	30.9	3	780	21.3	52	11300	299.3	59.2	28	42	-
CCBEL504 A 4	43.2	47.2	31.8	4	1040	28.4	53	17370	199.5	38.8	28	54	-
CCBEL504 B 4	50.5	56.0	37.8	4	1040	26.3	53	16120	299.3	58.3	28	54	-
CCBEL504 C 4	55.2	60.5	41.2	4	1040	24.6	53	15070	399.1	77.7	28	54	-

Model	Nominal capacities HFC DX				Blow-through AC fans 400/50/3							Connections		Stock model
	DT1 +2/-8 °C	SC2	SC3	SC4	fan power	air throw	sound pressure	air flow	coil surface	Int. volume	in	out		
CCBE	kW	kW	kW	kW	nr.	W	m	dB(A)	m <sup>3</sup> /h	m <sup>2</sup>	dm <sup>3</sup>	mm	mm	
Fin spacing 7 mm, fan speed H														
CCBEH301 A 7	2.1	1.6	1.2	1.0	1	68	7.3	42	1212	5.5	2.0	12	16	-
CCBEH301 B 7	2.7	2.0	1.6	1.3	1	68	6.9	42	1146	8.2	3.1	12	16	-
CCBEH301 C 7	3.1	2.3	1.9	1.5	1	68	6.6	42	1090	11.0	4.1	16	18	-
CCBEH302 A 7	4.2	3.1	2.5	2.0	2	136	10.3	45	2425	11.0	3.6	16	18	-
CCBEH302 B 7	5.4	4.0	3.2	2.6	2	136	9.8	45	2292	16.4	5.4	16	18	-
CCBEH302 C 7	6.3	4.6	3.7	3.1	2	136	9.3	45	2180	21.9	7.2	22	28	-
CCBEH303 A 7	6.3	4.6	3.7	3.0	3	204	12.7	47	3637	16.4	5.2	22	28	-
CCBEH303 B 7	8.2	6.1	4.8	4.0	3	204	12.0	47	3439	24.7	7.8	22	28	-
CCBEH303 C 7	9.3	7.0	5.6	4.6	3	204	11.4	47	3270	32.9	10.4	22	28	-
CCBEH304 A 7	8.5	6.3	5.0	4.1	4	272	14.6	48	4849	21.9	6.7	22	28	-
CCBEH304 B 7	10.8	8.0	6.4	5.2	4	272	13.8	48	4585	32.9	10.1	22	28	-
CCBEH351 A 7	3.9	2.9	2.3	1.8	1	170	11.4	48	2400	8.8	3.1	12	16	-
CCBEH351 B 7	5.1	3.8	3.0	2.4	1	170	10.9	48	2294	13.2	4.7	16	18	-
CCBEH351 C 7	5.9	4.4	3.5	2.9	1	170	10.5	48	2201	17.5	6.3	16	22	-
CCBEH352 A 7	7.8	5.8	4.5	3.7	2	340	16.2	51	4800	17.5	5.6	16	22	-
CCBEH352 B 7	9.7	7.3	5.6	4.5	2	340	15.5	51	4589	26.3	8.5	16	22	-
CCBEH352 C 7	11.9	8.9	7.1	5.8	2	340	14.8	51	4402	35.1	11.3	22	28	-
CCBEH353 A 7	11.7	8.6	6.8	5.6	3	510	19.8	53	7201	26.3	8.1	22	28	-
CCBEH353 B 7	15.2	11.3	8.9	7.3	3	510	18.9	53	6883	39.4	12.2	22	28	-
CCBEH353 C 7	17.3	13.0	10.1	8.2	3	510	18.2	53	6603	52.6	16.3	22	28	-
CCBEH354 A 7	15.5	11.5	9.1	7.4	4	680	22.9	54	9601	35.1	10.7	22	28	-
CCBEH354 B 7	19.5	14.7	11.3	9.0	4	680	21.9	54	9177	52.6	16.0	22	28	-

Model	Nominal capacities HFC DX				Blow-through AC fans 400/50/3							Connections		Stock model
	DT1 +2/-8 °C	SC2	SC3	SC4	fan power nr.	air throw W	sound pressure dB(A)	air flow m <sup>3</sup> /h	coil surface m <sup>2</sup>	Int. volume dm <sup>3</sup>	in mm	out mm		
CCBE	kW	kW	kW	kW										
Fin spacing 7 mm, fans speed H														
CCBEH401 A 7	4.9	3.6	2.8	2.3	1	229	14.3	55	3194	9.9	3.5	16	18	-
CCBEH401 B 7	6.3	4.7	3.7	3.0	1	229	13.7	55	3042	14.8	5.3	16	18	-
CCBEH401 C 7	7.5	5.6	4.4	3.6	1	229	13.0	55	2904	19.7	7.0	16	22	-
CCBEH402 A 7	9.7	7.2	5.6	4.5	2	458	20.3	58	6389	19.7	6.3	16	22	-
CCBEH402 B 7	12.1	9.1	6.9	5.5	2	458	19.3	58	6085	29.6	9.5	16	22	-
CCBEH402 C 7	15.0	11.2	8.9	7.3	2	458	18.4	58	5807	39.4	12.7	22	35	-
CCBEH403 A 7	14.7	10.8	8.5	7.0	3	687	24.8	60	9583	29.6	9.2	22	28	-
CCBEH403 B 7	19.0	14.2	11.1	9.0	3	687	23.7	60	9127	44.4	13.8	22	28	-
CCBEH403 C 7	21.6	16.3	12.6	10.0	3	687	22.6	60	8711	59.2	18.4	22	28	-
CCBEH404 A 7	19.4	14.4	11.2	9.1	4	916	28.7	61	12780	39.4	12.0	22	28	-
CCBEH404 B 7	24.2	18.3	13.9	11.1	4	916	27.3	61	12170	59.2	18.0	22	28	-
CCBEH404 C 7	28.8	21.7	16.8	13.4	4	916	26.1	61	11610	78.9	24.0	22	35	-
CCBEH501 A 7	10.3	7.6	5.8	4.7	1	720	23.0	55	7037	29.7	11.1	16	35	-
CCBEH501 B 7	13.7	10.1	7.8	6.3	1	720	21.9	55	6691	44.5	16.7	22	35	-
CCBEH501 C 7	15.9	11.8	9.2	7.4	1	720	20.9	55	6386	59.4	22.3	22	42	-
CCBEH502 A 7	20.0	14.9	11.3	9.0	2	1440	32.5	58	14070	59.4	20.4	22	42	-
CCBEH502 B 7	27.3	20.2	15.7	12.6	2	1440	30.9	58	13380	89.0	30.5	28	42	-
CCBEH502 C 7	31.8	23.7	18.4	14.8	2	1440	29.5	58	12770	118.7	40.8	28	42	-
CCBEH503 A 7	31.1	22.9	17.6	14.2	3	2160	39.8	60	21110	89.0	29.6	28	42	-
CCBEH503 B 7	38.0	28.8	21.7	17.1	3	2160	37.9	60	20070	133.5	44.4	28	42	-
CCBEH503 C 7	47.8	35.6	27.7	22.3	3	2160	36.1	60	19160	178.1	59.2	28	42	-
CCBEH504 A 7	41.5	30.4	23.5	19.0	4	2880	46.0	61	28150	118.7	38.8	28	54	-
CCBEH504 B 7	53.6	40.0	30.7	24.6	4	2880	43.7	61	26760	178.1	58.3	28	54	-
CCBEH504 C 7	63.7	47.5	36.9	29.7	4	2880	41.7	61	25540	237.4	77.7	28	54	-
Fin spacing 7 mm, fan speed L														
CCBEL501 A 7	8.1	5.9	4.6	3.7	1	260	15.2	47	4644	29.7	11.1	16	35	-
CCBEL501 B 7	10.5	7.7	6.0	4.9	1	260	14.4	47	4413	44.5	16.7	22	35	-
CCBEL501 C 7	12.1	9.0	7.1	5.7	1	260	13.8	47	4211	59.4	22.3	22	42	-
CCBEL502 A 7	15.9	11.8	9.1	7.4	2	520	21.5	50	9288	59.4	20.4	22	42	-
CCBEL502 B 7	21.0	15.4	12.1	9.9	2	520	20.4	50	8825	89.0	30.5	28	42	-
CCBEL502 C 7	24.2	17.9	14.2	11.5	2	520	19.5	50	8422	118.7	40.8	28	42	-
CCBEL503 A 7	24.3	17.8	13.9	11.3	3	780	26.3	52	13930	89.0	29.6	28	42	-
CCBEL503 B 7	30.2	22.7	17.5	14.0	3	780	25.0	52	13240	133.5	44.4	28	42	-
CCBEL503 C 7	36.3	26.9	21.3	17.3	3	780	23.8	52	12630	178.1	59.2	28	42	-
CCBEL504 A 7	32.3	23.6	18.4	15.0	4	1040	30.3	53	18580	118.7	38.8	28	54	-
CCBEL504 B 7	41.6	30.9	24.2	19.6	4	1040	28.8	53	17650	178.1	58.3	28	54	-
CCBEL504 C 7	48.4	35.9	28.4	23.1	4	1040	27.5	53	16840	237.4	77.7	28	54	-

Model	Nominal capacities HFC DX				Blow-through AC fans 400/50/3							Connections		Stock model
	DT1 +2/-8 °C kW	SC2 kW	SC3 kW	SC4 kW	fan power nr. W	air throw m	sound pressure dB(A)	air flow m <sup>3</sup> /h	coil surface m <sup>2</sup>	Int. volume dm <sup>3</sup>	OD in mm	OD out mm		
<b>Fin spacing 10 mm, fan speed H</b>														
CCBEH501 A 10	8.5	6.3	4.8	3.9	1	720	23.47	55	7184	21.59	11.1	16	35	-
CCBEH501 B 10	11.6	8.5	6.6	5.4	1	720	22.5	55	6886	32.39	16.7	22	35	-
CCBEH501 C 10	13.9	10.3	8.0	6.5	1	720	21.62	55	6620	43.19	22.3	22	42	-
CCBEH502 A 10	16.8	12.5	9.6	7.7	2	1440	33.19	58	14370	43.19	20.4	22	42	-
CCBEH502 B 10	23.2	17.1	13.3	10.8	2	1440	31.81	58	13770	64.78	30.5	28	42	-
CCBEH502 C 10	27.9	20.7	16.1	13.0	2	1440	30.58	58	13240	86.38	40.8	28	42	-
CCBEH503 A 10	25.7	18.8	14.6	11.8	3	2160	40.65	60	21550	64.78	29.6	28	42	-
CCBEH503 B 10	33.2	24.9	19.0	15.1	3	2160	38.96	60	20660	97.17	44.4	28	42	-
CCBEH503 C 10	41.8	31.0	24.2	19.6	3	2160	37.45	60	19860	129.6	59.2	28	42	-
CCBEH504 A 10	34.2	24.9	19.3	15.7	4	2880	46.94	61	28740	86.38	38.8	28	54	-
CCBEH504 B 10	45.9	34.1	26.4	21.3	4	2880	44.99	61	27550	129.6	58.3	28	54	-
CCBEH504 C 10	55.8	41.4	32.3	26.1	4	2880	43.25	61	26480	172.8	77.7	28	54	-
<b>Fin spacing 10 mm, fan speed L</b>														
CCBEL501 A 10	6.7	4.9	3.8	3.1	1	260	15.5	47	4749	21.6	11.1	16	35	-
CCBEL501 B 10	8.9	6.5	5.1	4.2	1	260	14.9	47	4548	32.4	16.7	22	35	-
CCBEL501 C 10	10.7	7.9	6.2	5.1	1	260	14.3	47	4372	43.2	22.3	22	42	-
CCBEL502 A 10	13.3	9.9	7.7	6.2	2	520	21.9	50	9497	43.2	20.4	22	42	-
CCBEL502 B 10	17.9	13.2	10.4	8.5	2	520	21.0	50	9096	64.8	30.5	28	42	-
CCBEL502 C 10	21.3	15.8	12.5	10.2	2	520	20.2	50	8743	86.4	40.8	28	42	-
CCBEL503 A 10	20.1	14.7	11.5	9.4	3	780	26.9	52	14250	64.8	29.6	28	42	-
CCBEL503 B 10	26.3	19.6	15.2	12.3	3	780	25.7	52	13640	97.2	44.4	28	42	-
CCBEL503 C 10	32.0	23.7	18.7	15.3	3	780	24.7	52	13110	129.6	59.2	28	42	-
CCBEL504 A 10	26.7	19.4	15.2	12.4	4	1040	31.0	53	18990	86.4	38.8	28	54	-
CCBEL504 B 10	35.8	26.4	20.7	16.9	4	1040	29.7	53	18190	129.6	58.3	28	54	-
CCBEL504 C 10	42.7	31.6	24.9	20.4	4	1040	28.6	53	17490	172.8	77.7	28	54	-
<b>Fin spacing 12 mm, fan speed H</b>														
CCBEH501 A 12	7.8	5.7	4.4	3.6	1	720	23.6	55	7228	18.5	11.1	16	35	-
CCBEH501 B 12	10.7	7.8	6.1	5.0	1	720	22.7	55	6945	27.7	16.7	22	35	-
CCBEH501 C 12	13.0	9.6	7.5	6.1	1	720	21.9	55	6691	36.9	22.3	22	42	-
CCBEH502 A 12	15.5	11.5	8.8	7.1	2	1440	33.4	58	14460	36.9	20.4	22	42	-
CCBEH502 B 12	21.4	15.8	12.3	10.0	2	1440	32.1	58	13890	55.4	30.5	28	42	-
CCBEH502 C 12	26.0	19.3	15.0	12.2	2	1440	30.9	58	13380	73.8	40.8	28	42	-
CCBEH503 A 12	23.5	17.2	13.3	10.8	3	2160	40.9	60	21680	55.4	29.6	28	42	-
CCBEH503 B 12	31.0	23.2	17.8	14.2	3	2160	39.3	60	20840	83.0	44.4	28	42	-
CCBEH503 C 12	39.1	28.9	22.6	18.3	3	2160	37.9	60	20070	110.7	59.2	28	42	-
CCBEH504 A 12	31.2	22.7	17.6	14.3	4	2880	47.2	61	28910	73.8	38.8	28	54	-
CCBEH504 B 12	42.6	31.5	24.5	19.8	4	2880	45.4	61	27780	110.7	58.3	28	54	-
CCBEH504 C 12	52.1	38.6	30.1	24.4	4	2880	43.7	61	26760	147.6	77.7	28	54	-
<b>Fin spacing 12 mm, fan speed L</b>														
CCBEL501 A 12	6.1	4.5	3.5	2.9	1	260	15.62	47	4781	18.45	11.1	16	35	-
CCBEL501 B 12	8.3	6.0	4.8	3.9	1	260	15.0	47	4590	27.68	16.7	22	35	-
CCBEL501 C 12	10.0	7.4	5.8	4.7	1	260	14.45	47	4423	36.9	22.3	22	42	-
CCBEL502 A 12	12.3	9.0	7.1	5.7	2	520	22.1	50	9562	36.9	20.4	22	42	-
CCBEL502 B 12	16.6	12.2	9.6	7.8	2	520	21.2	50	9181	55.4	30.5	28	42	-
CCBEL502 C 12	20.0	14.8	11.7	9.5	2	520	20.4	50	8845	73.8	40.8	28	42	-
CCBEL503 A 12	18.4	13.5	10.5	8.6	3	780	27.1	52	14340	55.4	29.6	28	42	-
CCBEL503 B 12	24.5	18.3	14.2	11.5	3	780	26.0	52	13770	83.0	44.4	28	42	-
CCBEL503 C 12	30.0	22.1	17.5	14.3	3	780	25.0	52	13270	110.7	59.2	28	42	-
CCBEL504 A 12	24.4	17.8	13.9	11.3	4	1040	31.2	53	19120	73.8	38.8	28	54	-
CCBEL504 B 12	33.2	24.5	19.2	15.7	4	1040	30.0	53	18360	110.7	58.3	28	54	-
CCBEL504 C 12	40.0	29.5	23.3	19.1	4	1040	28.9	53	17690	147.6	77.7	28	54	-

Model	Nominal capacities R404A		AC fans 400/50/3									Connections	
			Capacity SC 15		fan power		sound pressure		air flow		coil surface	Int. volume	OD
	D kW	Y kW	nr.	D W	Y W	D dB(A)	Y dB(A)	D m <sup>3</sup> /h	Y m <sup>3</sup> /h	m <sup>2</sup>	dm <sup>3</sup>	in mm	out mm
Noise level S													
AGS501 A	20.7	19.1	1	690	490	51	48	7761	6804	29.3	3.3	16	16
AGS501 B	25.9	23.7	1	690	490	51	48	7349	6391	43.9	4.9	16	16
AGS501 C	29.0	26.0	1	690	490	51	48	6986	6036	58.6	6.5	18	18
AGS502 A	41.6	38.6	2	1380	980	54	51	15520	13610	58.6	6.2	22	22
AGS502 B	52.5	47.9	2	1380	980	54	51	14700	12780	87.8	9.3	28	28
AGS502 C	58.1	52.2	2	1380	980	54	51	13970	12070	117.1	12.2	28	28
AGS503 A	62.6	58.2	3	2070	1470	56	53	23280	20410	87.8	9.1	28	28
AGS503 B	79.1	72.1	3	2070	1470	56	53	22050	19170	131.8	13.9	35	35
AGS503 C	88.9	79.9	3	2070	1470	56	53	20960	18110	175.7	18.1	35	35
AGS504 A	83.0	77.4	4	2760	1960	57	54	31040	27220	117.1	12.3	35	35
AGS504 B	103.9	94.5	4	2760	1960	57	54	29400	25560	175.7	17.9	35	35
AGS504 C	118.4	107.0	4	2760	1960	57	54	27940	24150	234.2	23.4	35	35
AGS631 A	29.9	26.8	1	1250	840	51	46	11510	9607	40.7	4.6	18	18
AGS631 B	37.9	33.4	1	1250	840	51	46	11000	9024	61.0	6.9	22	22
AGS631 C	43.2	37.1	1	1250	840	51	46	10530	8517	81.3	9	22	22
AGS632 A	60.4	54.0	2	2500	1680	54	49	23020	19210	81.3	8.8	28	28
AGS632 B	76.1	66.8	2	2500	1680	54	49	22000	18050	122.0	13.5	35	35
AGS632 C	86.2	73.8	2	2500	1680	54	49	21070	17030	162.7	17.4	35	35
AGS633 A	89.0	79.4	3	3750	2520	56	51	34530	28820	122.0	13.2	35	35
AGS633 B	115.0	101.3	3	3750	2520	56	51	33000	27070	183.0	19	35	35
AGS633 C	131.1	112.5	3	3750	2520	56	51	31600	25550	244.0	25.6	42	42
AGS634 A	121.3	109.3	4	5000	3360	57	52	46040	38430	162.7	16.9	35	35
AGS634 B	152.7	133.8	4	5000	3360	57	52	43990	36100	244.0	25.3	42	42
AGS634 C	172.8	147.8	4	5000	3360	57	52	42140	34070	325.3	32.9	42	42
AGS635 A	151.8	136.8	5	6250	4200	58	53	57560	48040	203.3	21.4	42	42
AGS635 B	192.7	169.1	5	6250	4200	58	53	54990	45120	305.0	32.4	54	54
AGS635 C	218.4	187.0	5	6250	4200	58	53	52670	42590	406.6	41.9	54	54
AGS636 A	181.3	163.9	6	7500	5040	58	53	69070	57640	244.0	26.7	54	54
AGS636 B	231.5	203.7	6	7500	5040	58	53	65990	54140	366.0	38	54	54
AGS636 C	263.3	225.6	6	7500	5040	58	53	63210	51100	488.0	49.3	54	54

Model	Nominal capacities R404A		AC fans 400/50/3									Connections	
			fan		Sound		air		coil	Int.	OD		
	Capacity SC 15		nr.	power		pressure		flow		surface	volume	in	out
AGL	D kW	Y kW		D W	Y W	D dB(A)	Y dB(A)	D m <sup>3</sup> /h	Y m <sup>3</sup> /h	m <sup>2</sup>	dm <sup>3</sup>	mm	mm
Noise level L													
AGL501 A	15.5	14.2	1	260	190	39	37	4891	4268	29.3	3.3	16	16
AGL501 B	19.1	17.2	1	260	190	39	37	4629	4008	43.9	4.9	16	16
AGL501 C	20.5	18.2	1	260	190	39	37	4394	3779	58.6	6.5	18	18
AGL502 A	31.2	28.5	2	520	380	42	40	9783	8536	58.6	6.2	22	22
AGL502 B	38.4	34.5	2	520	380	42	40	9258	8016	87.8	9.3	28	28
AGL502 C	41.0	36.3	2	520	380	42	40	8789	7559	117.1	12.2	28	28
AGL503 A	47.7	43.7	3	780	570	44	42	14670	12800	87.8	9.1	28	28
AGL503 B	57.7	51.9	3	780	570	44	42	13890	12020	131.8	13.9	35	35
AGL503 C	62.9	55.8	3	780	570	44	42	13180	11340	175.7	18.1	35	35
AGL504 A	62.5	57.1	4	1040	760	45	43	19570	17070	117.1	12.3	35	35
AGL504 B	75.3	67.7	4	1040	760	45	43	18520	16030	175.7	17.9	35	35
AGL504 C	84.3	74.8	4	1040	760	45	43	17580	15120	234.2	23.4	35	35
AGL631 A	25.8	22.6	1	600	400	45	40	9009	7254	40.7	4.6	18	18
AGL631 B	32.0	27.2	1	600	400	45	40	8460	6686	61.0	6.9	22	22
AGL631 C	35.4	29.4	1	600	400	45	40	7983	6221	81.3	9.0	22	22
AGL632 A	52.0	45.5	2	1200	800	48	43	18020	14510	81.3	8.8	28	28
AGL632 B	63.9	54.1	2	1200	800	48	43	16920	13370	122.0	13.5	35	35
AGL632 C	70.3	58.2	2	1200	800	48	43	15970	12440	162.7	17.4	35	35
AGL633 A	76.4	67.3	3	1800	1200	50	45	27030	21760	122.0	13.2	35	35
AGL633 B	97.1	82.5	3	1800	1200	50	45	25380	20060	183.0	19	35	35
AGL633 C	107.5	88.9	3	1800	1200	50	45	23950	18660	244.0	25.6	42	42
AGL634 A	105.2	91.2	4	2400	1600	51	46	36040	29020	162.7	16.9	35	35
AGL634 B	128.0	108.4	4	2400	1600	51	46	33840	26740	244.0	25.3	42	42
AGL634 C	140.8	116.4	4	2400	1600	51	46	31930	24880	325.3	32.9	42	42
AGL635 A	131.6	115.2	5	3000	2000	52	47	45050	36270	203.3	21.4	42	42
AGL635 B	161.9	137.2	5	3000	2000	52	47	42300	33430	305.0	32.4	54	54
AGL635 C	178.1	147.4	5	3000	2000	52	47	39920	31100	406.6	41.9	54	54
AGL636 A	157.9	138.6	6	3600	2400	52	47	54060	43530	244.0	26.7	54	54
AGL636 B	195.0	165.6	6	3600	2400	52	47	50760	40120	366.0	38.0	54	54
AGL636 C	215.5	178.1	6	3600	2400	52	47	47900	37320	488.0	49.3	54	54

Model	Nominal capacities R404A		AC fans 400/50/3									Connections	
			fan		Sound		air		coil	Int.	OD		
	Capacity SC 15		nr.	power	power	pressure	pressure	flow	flow	surface	volume	in	out
AGQ	D kW	Y kW		D W	Y W	D dB(A)	Y dB(A)	D m <sup>3</sup> /h	Y m <sup>3</sup> /h	m <sup>2</sup>	dm <sup>3</sup>	mm	mm
Noise level Q													
AGQ501 A	13.1	10.6	1	150	80	29	23	3763	2771	29.3	3.3	16	16
AGQ501 B	15.7	12.3	1	150	80	29	23	3530	2589	43.9	4.9	16	16
AGQ501 C	16.4	12.6	1	150	80	29	23	3327	2433	58.6	6.5	18	18
AGQ502 A	26.2	21.2	2	300	160	32	26	7527	5542	58.6	6.2	22	22
AGQ502 B	31.3	24.7	2	300	160	32	26	7060	5178	87.8	9.3	28	28
AGQ502 C	32.8	25.1	2	300	160	32	26	6654	4866	117.1	12.2	28	28
AGQ503 A	40.2	32.5	3	450	240	34	28	11290	8313	87.8	9.1	28	28
AGQ503 B	47.1	37.1	3	450	240	34	28	10590	7767	131.8	13.9	35	35
AGQ503 C	50.2	38.5	3	450	240	34	28	9981	7299	175.7	18.1	35	35
AGQ504 A	52.5	42.4	4	600	320	35	29	15050	11080	117.1	12.3	35	35
AGQ504 B	61.5	48.4	4	600	320	35	29	14120	10360	175.7	17.9	35	35
AGQ504 C	67.6	51.7	4	600	320	35	29	13310	9732	234.2	23.4	35	35
AGQ631 A	19.0	-	1	235	-	31	-	5537	-	40.7	4.6	18	18
AGQ631 B	22.8	-	1	235	-	31	-	5248	-	61.0	6.9	22	22
AGQ631 C	24.7	-	1	235	-	31	-	4993	-	81.3	9.0	22	22
AGQ632 A	38.2	-	2	470	-	34	-	11070	-	81.3	8.8	28	28
AGQ632 B	45.3	-	2	470	-	34	-	10500	-	122.0	13.5	35	35
AGQ632 C	48.8	-	2	470	-	34	-	9986	-	162.7	17.4	35	35
AGQ633 A	55.9	-	3	705	-	36	-	16610	-	122.0	13.2	35	35
AGQ633 B	69.1	-	3	705	-	36	-	15740	-	183.0	19	35	35
AGQ633 C	74.6	-	3	705	-	36	-	14980	-	244.0	25.6	42	42
AGQ634 A	76.4	-	4	940	-	37	-	22150	-	162.7	16.9	35	35
AGQ634 B	90.6	-	4	940	-	37	-	20990	-	244.0	25.3	42	42
AGQ634 C	97.7	-	4	940	-	37	-	19970	-	325.3	32.9	42	42
AGQ635 A	96.7	-	5	1175	-	38	-	27690	-	203.3	21.4	42	42
AGQ635 B	114.7	-	5	1175	-	38	-	26240	-	305.0	32.4	54	54
AGQ635 C	123.6	-	5	1175	-	38	-	24970	-	406.6	41.9	54	54
AGQ636 A	116.6	-	6	1410	-	38	-	33220	-	244.0	26.7	54	54
AGQ636 B	138.3	-	6	1410	-	38	-	31490	-	366.0	38.0	54	54
AGQ636 C	149.4	-	6	1410	-	38	-	29960	-	488.0	49.3	54	54

Model	Nominal capacities R404A Capacity SC 15 kW	AC fans 230/50/1						Connections	
		nr.	fan power W	sound pressure dB(A)	air flow m <sup>3</sup> /h	coil surface m <sup>2</sup>	Int. volume dm <sup>3</sup>	in mm	out mm
<b>AGS</b>									
<b>Noise level S</b>									
AGS351 A	7.6	1	145	36	2662	12.2	1.5	16	16
AGS351 B	9.4	1	145	36	2490	18.3	2.2	16	16
AGS351 C	10.4	1	145	36	2337	24.4	2.9	16	16
AGS352 A	15.4	2	290	39	5323	24.4	2.6	16	16
AGS352 B	18.8	2	290	39	4979	36.6	3.9	16	16
AGS352 C	20.8	2	290	39	4675	48.8	5.1	16	16
AGS353 A	23.2	3	435	41	7985	36.6	3.7	16	16
AGS353 B	28.6	3	435	41	7469	54.9	5.6	18	18
AGS353 C	31.5	3	435	41	7012	73.2	7.5	22	22
AGS501 A	20.3	1	710	51	7512	29.3	3.3	16	16
AGS501 B	25.3	1	710	51	7085	43.9	4.9	16	16
AGS501 C	28.1	1	710	51	6702	58.6	6.5	18	18
AGS502 A	40.8	2	1420	54	15020	58.6	6.2	22	22
AGS502 B	51.3	2	1420	54	14170	87.8	9.3	28	28
AGS502 C	56.4	2	1420	54	13400	117.1	12.2	28	28
AGS503 A	61.5	3	2130	56	22540	87.8	9.1	28	28
AGS503 B	77.2	3	2130	56	21260	131.8	13.9	35	35
AGS503 C	86.3	3	2130	56	20110	175.7	18.1	35	35
AGS504 A	81.4	4	2840	57	30050	117.1	12.3	35	35
AGS504 B	101.3	4	2840	57	28340	175.7	17.9	35	35
AGS504 C	115.0	4	2840	57	26810	234.2	23.4	35	35



Model	Nominal capacities R404A		AC fans 230/50/1					Connections	
	Capacity SC 15	nr.	fan	sound	air	coil	Int.	OD	
			power	pressure	flow	surface	volume	in	out
AGL	kW		W	dB(A)	m <sup>3</sup> /h	m <sup>2</sup>	dm <sup>3</sup>	mm	mm
Noise level L									
AGL351 A	5.6	1	65	27	1663	12.2	1.5	16	16
AGL351 B	6.7	1	65	27	1539	18.3	2.2	16	16
AGL351 C	7.1	1	65	27	1434	24.4	2.9	16	16
AGL352 A	11.5	2	130	30	3326	24.4	2.6	16	16
AGL352 B	13.2	2	130	30	3078	36.6	3.9	16	16
AGL352 C	14.3	2	130	30	2868	48.8	5.1	16	16
AGL353 A	17.1	3	195	32	4989	36.6	3.7	16	16
AGL353 B	20.3	3	195	32	4618	54.9	5.6	18	18
AGL353 C	21.6	3	195	32	4302	73.2	7.5	22	22
AGL501 A	15.1	1	220	37	4671	29.3	3.3	16	16
AGL501 B	18.4	1	220	37	4402	43.9	4.9	16	16
AGL501 C	19.6	1	220	37	4165	58.6	6.5	18	18
AGL502 A	30.3	2	440	40	9341	58.6	6.2	22	22
AGL502 B	37.0	2	440	40	8804	87.8	9.3	28	28
AGL502 C	39.3	2	440	40	8330	117.1	12.2	28	28
AGL503 A	46.3	3	660	42	14010	87.8	9.1	28	28
AGL503 B	55.6	3	660	42	13210	131.8	13.9	35	35
AGL503 C	60.3	3	660	42	12490	175.7	18.1	35	35
AGL504 A	60.6	4	880	43	18680	117.1	12.3	35	35
AGL504 B	72.6	4	880	43	17610	175.7	17.9	35	35
AGL504 C	80.8	4	880	43	16660	234.2	23.4	35	35
AGL631 A	25.4	1	600	45	8746	40.7	4.6	18	18
AGL631 B	31.3	1	600	45	8197	61.0	6.9	22	22
AGL631 C	34.5	1	600	45	7726	81.3	9.0	22	22
AGL632 A	51.1	2	1200	48	17490	81.3	8.8	28	28
AGL632 B	62.5	2	1200	48	16390	122.0	13.5	35	35
AGL632 C	68.6	2	1200	48	15450	162.7	17.4	35	35
AGL633 A	75.6	3	1800	50	26240	122.0	13.2	35	35
AGL633 B	95.1	3	1800	50	24590	183.0	19	35	35
AGL633 C	104.9	3	1800	50	23180	244.0	25.6	42	42
AGL634 A	103.3	4	2400	51	34980	162.7	16.9	35	35
AGL634 B	125.2	4	2400	51	32790	244.0	25.3	42	42
AGL634 C	137.3	4	2400	51	30900	325.3	32.9	42	42
AGL635 A	129.3	5	3000	52	43730	203.3	21.4	42	42
AGL635 B	158.4	5	3000	52	40980	305.0	32.4	54	54
AGL635 C	173.7	5	3000	52	38630	406.6	41.9	54	54
AGL636 A	155.2	6	3600	52	52480	244.0	26.7	54	54
AGL636 B	190.9	6	3600	52	49180	366.0	38.0	54	54
AGL636 C	210.3	6	3600	52	46360	488.0	49.3	54	54

Model	Nominal capacities R404A Capacity SC 15 kW	AC fans 230/50/1					Connections		
		nr.	fan power W	sound pressure dB(A)	air flow m <sup>3</sup> /h	coil surface m <sup>2</sup>	Int. volume dm <sup>3</sup>	OD in out mm mm	
Noise level Q									
AGQ501 A	13.0	1	130	27	3707	29.3	3.3	16	16
AGQ501 B	15.4	1	130	27	3462	43.9	4.9	16	16
AGQ501 C	16.1	1	130	27	3250	58.6	6.5	18	18
AGQ502 A	26.0	2	260	30	7413	58.6	6.2	22	22
AGQ502 B	31.0	2	260	30	6924	87.8	9.3	28	28
AGQ502 C	32.1	2	260	30	6499	117.1	12.2	28	28
AGQ503 A	39.8	3	390	32	11120	87.8	9.1	28	28
AGQ503 B	46.4	3	390	32	10390	131.8	13.9	35	35
AGQ503 C	49.3	3	390	32	9749	175.7	18.1	35	35
AGQ504 A	52.0	4	520	33	14830	117.1	12.3	35	35
AGQ504 B	60.6	4	520	33	13850	175.7	17.9	35	35
AGQ504 C	66.0	4	520	33	13000	234.2	23.4	35	35
AGQ631 A	19.0	1	140	38	5537	40.7	4.6	18	18
AGQ631 B	22.8	1	140	38	5248	61.0	6.9	22	22
AGQ631 C	24.7	1	140	38	4993	81.3	9.0	22	22
AGQ632 A	38.2	2	280	41	11070	81.3	8.8	28	28
AGQ632 B	45.3	2	280	41	10500	122.0	13.5	35	35
AGQ632 C	48.8	2	280	41	9986	162.7	17.4	35	35
AGQ633 A	55.9	3	420	43	16610	122.0	13.2	35	35
AGQ633 B	69.1	3	420	43	15740	183.0	19	35	35
AGQ633 C	74.6	3	420	43	14980	244.0	25.6	42	42
AGQ634 A	76.4	4	560	44	22150	162.7	16.9	35	35
AGQ634 B	90.6	4	560	44	20990	244.0	25.3	42	42
AGQ634 C	97.7	4	560	44	19970	325.3	32.9	42	42
AGQ635 A	96.7	5	700	45	27690	203.3	21.4	42	42
AGQ635 B	114.7	5	700	45	26240	305.0	32.4	54	54
AGQ635 C	123.6	5	700	45	24970	406.6	41.9	54	54
AGQ636 A	116.6	6	840	45	33220	244.0	26.7	54	54
AGQ636 B	138.3	6	840	45	31490	366.0	38.0	54	54
AGQ636 C	149.4	6	840	45	29960	488.0	49.3	54	54



## Other Alfa Laval products

### Industrial air coolers

In industrial refrigeration, standard commercial air cooler solutions often fall short, as every application has its own unique requirements. The Arctigo industrial air cooler platform offers an extremely wide range of single and dual discharge industrial air coolers and dedicated ranges for agricultural storage, shock cooling, banana ripening and data center cooling.



### Industrial condensers and gas coolers

Alfa Laval's industrial air-cooled condensers for all HFO/HFC refrigerant and ammonia systems, in horizontal or vertical setup or as V-type condensers. Available with either copper or stainless steel tubing. The Alfa Laval condenser portfolio includes a variety of design options and accessories.



### Industrial liquid coolers and radiators (Alfa-V, Blue, FBL, Solar)

Our range covers dry coolers for HVAC & REF applications, radiators for heavy industrial cooling applications in process and power industries and dedicated ranges for transformer oil cooling. Our industrial liquid coolers are available with either copper or stainless steel tubing. We supply both standardized as well as fully customized industrial liquid coolers. The Alfa Laval product portfolio includes a variety of design options and accessories.



**Alfa Laval in brief**

Alfa Laval is a leading global provider of specialized products and engineered solutions.

Our equipment, systems and services are dedicated to helping customers optimize the performance of their processes. Time and time again.

We help our customers to heat, cool, separate and transport products such as oil, water, chemicals, beverages, food-stuffs, starch and pharmaceuticals.

Our worldwide organization works closely with customers in some 100 countries to help them stay ahead.

**How to contact Alfa Laval**

Up-to-date contact details for all countries are always available on our corporate website at [www.alfalaval.com](http://www.alfalaval.com). You can also download product information and selection software.



[www.alfalaval.com](http://www.alfalaval.com)

Alfa Laval channel partner

